

# Structures ready-reckoner

*Analytical framework of structural reinforcement and seismic retrofitting with fibre reinforced polymer materials (FRP)*



QUALITY YOU CAN BUILD ON

[draco-edilizia.com](http://draco-edilizia.com)

Second edition

# Building without borders



**CONCRETE LINE** Additives for concrete

**FLOORING LINE** Product for concrete flooring

**WATERPROOFING LINE** Building waterproofing solutions

**REFURBISHMENT and RESTORATION LINE** Product for building restoration

**UNDERGROUND and TUNNELLING LINE** Product for special foundations and tunnels

**RENOVATION and BIOARCHITECTURE LINE** Renovation, insulation and house comfort

# TABLE OF CONTENTS

<b>INTRODUCTION:</b>	<b>PAGE 04</b>
The benefits and applications of FRP technology	
<b>1. REINFORCED CONCRETE</b>	<b>PAGE 08</b>
General description of typical issues related to reinforced concrete structural elements	
1.1 REINFORCED CONCRETE BEAM - Flexural strengthening with carbon fibre fabric	Page 10
1.2 REINFORCED CONCRETE BEAM - Flexural strengthening with carbon fibre plates	Page 12
1.3 REINFORCED CONCRETE BEAM - Shear strengthening with carbon fibre fabric	Page 14
1.4 REINFORCED CONCRETE BEAM - Flexural strengthening and compression restoring through pre-tensioning	Page 16
1.5 FLOOR SLAB IN BRICK-CEMENT - Flexural strengthening with carbon fibre plates	Page 18
1.6 REINFORCED CONCRETE PILLAR - Compressive strengthening through confinement with carbon fibre fabrics	Page 20
1.7 REINFORCED CONCRETE PILLAR - Combined bending and axial load strengthening and shear strengthening with plates and carbon fibre fabrics	Page 22
1.8 BEAM-PILLAR JUNCTION - Junction strengthening through confinement with carbon fibre fabrics	Page 24
1.9 REINFORCED CONCRETE WALLS - Shear strengthening with carbon fibre fabrics and plates	Page 26
1.10 MASONRY BUFFER WALLS AND FLOOR SLABS - Strengthening, anti-collapse reinforcement and enhancement of anti-seismic performance	Page 28
<b>2. MASONRY</b>	<b>PAGE 30</b>
General description of typical issues related to masonry structural elements	
2.1 MASONRY PILLAR - Compressive strengthening through confinement with carbon fibre fabrics	Page 32
2.2 PERIMETER WALL PANELS - Strengthening through wrapping with carbon fibre fabrics	Page 34
2.3 PERIMETER WALL PANELS - Vertical flexural strengthening	Page 36
2.4 PERIMETER WALL PANELS - Rinforzo a flessione orizzontale	Page 38
2.5 ORTHOGONAL MASONRY WALLS CONNECTION	Page 40
2.6 WALLS SUBJECTED TO SHEAR STRESS - Shear strengthening	Page 42
2.7 ARCHES - Intrados/extrados strengthening	Page 44
2.8 BARREL VAULTS - Intrados/extrados strengthening	Page 46
2.9 GROIN VAULTS - Intrados/extrados strengthening	Page 48
2.10 DOMES - Intrados/extrados strengthening	Page 50
2.11. ANCHORING DEVICES	Page 52
<b>3. WOOD</b>	<b>PAGE 54</b>
General description of typical issues related to masonry structural elements	
3.1 WOODEN BEAM - Flexural strengthening with carbon fibre fabric	Page 56
3.2 WOODEN BEAM - Flexural strengthening with carbon fibre plates	Page 58
<b>4. ITEM SPECIFICATIONS</b>	<b>PAGE 61</b>
4.0 Preparation	
4.0.1 Preparation of the reinforced concrete substrate	Page 62
4.0.2 Preparation of the masonry substrate	Page 63
4.1 Strengthening of structural elements with carbon fibre fabrics	Page 64
4.2 Strengthening of structural elements with carbon fibre pultruded plates	Page 68
4.3 Strengthening of structural elements with carbon fibre pultruded fabrics and plates	Page 70
4.4 Structural strengthening and reinforcement of wooden structure with carbon fibre fabrics	Page 74
4.5 Structural strengthening and reinforcement of wooden structure with carbon fibre plates	Page 76
4.6 Strengthening of structural elements with carbon fibre fabrics using ARMOGRIP aramid connectors	Page 78
4.7 Strengthening of structural elements with carbon fibre fabrics using aramid connectors coupled with ARMOSHIELD BC carbon bars	Page 80
4.8 Strengthening of structural elements through the pre-tensioning of ARMOSHIELD CFK carbon fibre plates	Page 82
4.9 Strengthening and seismic retrofitting of masonry buffer walls and floor slabs with anti-overturning and anti-collapse systems	Page 84
<b>5. ARMO PRODUCTS</b>	<b>PAGE 88</b>
<b>5. APPENDIX</b>	<b>PAGE 92</b>

# FRP TECHNOLOGY

## FRP AND COMPOSITE MATERIALS:

Lightness and resistance at the service of building renovation

“*Continuous fibre reinforced polymer materials (FRP) referred to in this document are composite, heterogeneous and anisotropic materials mainly showing a linear elastic behaviour up to failure. They are widely used to strengthen and reinforce civil structures. The benefits of FRP are many: lightness, high mechanical strength, anti-corrosive properties.*”

The previous quote, taken from the introduction of the technical document CNR Technical Document 200 R1/2013 REV. 15/05/2014, provides a very brief description of the characteristics of FRP technology materials used for structural reinforcements, by summarily examining their morphological and mechanical features and possible applications. However, professionals who are new to this sector do not immediately take into account the reinforcement solutions offered by FRP materials. Indeed, the mentioned CNR is not a didactic document, but rather a technical document containing calculation instructions addressed to those who already know the possible applications of this technology, although it contains a long chapter which describes the features of materials that make up the reinforcement system.

### FRP composite materials: what they are and what they are used for

Composite materials, initially used as structural materials in the aeronautical and aerospace sectors, since the middle of the last century have progressively spread to other areas so that they are also widely used in the sports, naval and civil engineering contexts. It was at the end of the 1970s that the use of composite materials in civil engineering began.

#### But what do FRP composite materials consist of?

The FRP (Fibre Reinforced Polymer) composite materials consist of continuous fibres of suitable materials immersed in a polymer matrix that holds them together and fixes them to the structure to be reinforced. The fibre has the task of withstanding the stresses, the matrix instead has the task of protecting the reinforcing fibres and transferring, to them, the external load. The fibres most used to produce composite materials are those made of **carbon, aramid, glass and basalt**.



### Why they are so effective

The FRP composite materials work only if subjected to tensile strength and are extremely resistant: **carbon fibre, for example, has a tensile strength 10 times higher than steel.**

The possibility of being able to orient the reinforcing fibres and their percentage in the actual directions in which the stresses act, permits the realization of composite materials characterized by a very high weight-to-performance ratio that permits results which would be unimaginable with traditional materials.

To obtain an effective reinforcement, however, it is not sufficient to use high-strength fibres: it is also essential to ensure good adhesion between the substrate and the reinforcement itself for a correct transmission of the tensions. **The adhesion is achieved through the use of structural resins applied in very thin layers on the fibre surface and on the substrate previously treated with an adhesion promoter.**

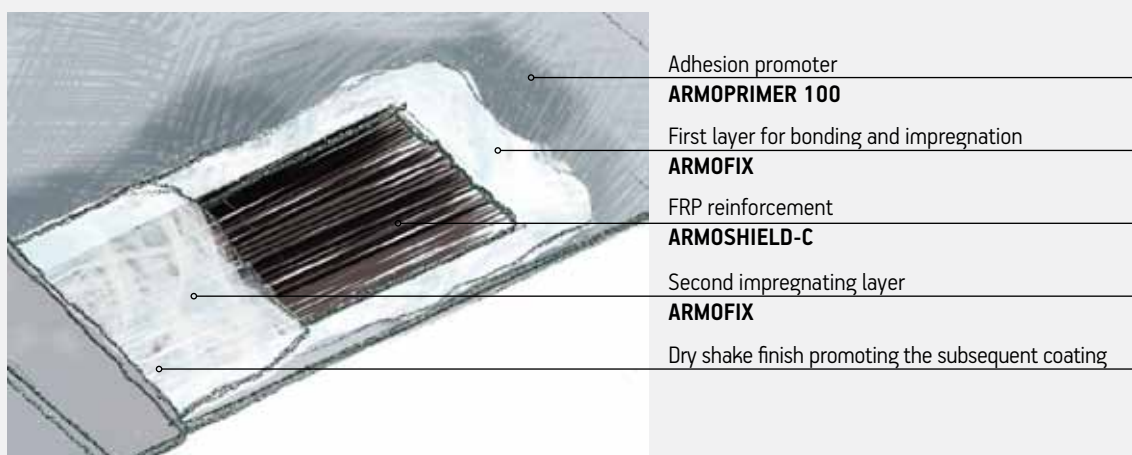

The main benefits of using the FRP technology are its lightness, the ease of installation and the high improvement of the load-bearing capacity that can be achieved with elements that are very small in comparison to the structural elements that need reinforcement, i.e. that do not modify its final appearance. Their use is particularly interesting from an anti-seismic point of view, because the resistance and flexibility of structures can be improved without increasing their mass thus maintaining anti-seismic action unaltered according to regulations.

### BENEFITS

- ✓ they do not produce additional loads on the structure
- ✓ they are quick to apply
- ✓ they can be applied without interrupting the activities in the areas below or above the intervention
- ✓ the result of the intervention is practically invisible and does not alter the aesthetics of the structure
- ✓ it does not change the geometry of the reinforced element
- ✓ high durability
- ✓ low chemical susceptibility
- ✓ lower site management charges
- ✓ Reversible intervention

# FRP TECHNOLOGY

## Is one product much the same as another?

No, the Ministerial Decree of 14/01/2008 (Technical Building Regulations) requires that the building materials are EC marked. Although the FRP reinforcement is not, strictly speaking, classifiable as a building material and there are as yet no harmonized standards, which would make the EC marking mandatory, it is opportune that the products are certified by laboratory tests (which must have ministerial authorization) and that subsequently the certificates of conformity are obtained by means of production controls. From July 2016 it will be mandatory to classify products according to the guidelines issued on 09.07.2015. Moreover, the CNR Technical Document 200 requires that 'the system' should be certified:



*The fabric and the adhesive used must be produced by the same company as it is **the fabric-adhesive combination** which is tested in the certification process*

## How they are used in the building industry

FRP composites are mainly used in all those parts of structures that are damaged by the stress present; they **serve to reinforce structurally the load-bearing elements** and parts of structures in reinforced **concrete - masonry - wood - steel** where the load-bearing capacity is impaired due to:

- degraded constituent materials which can cause the decrease of the resistant section and lower mechanical resistance;
- change in intended use which determines an overload not envisaged for the load-bearing elements;
- structural failures, strong impacts, fires or earthquakes.

**The main uses of FRP reinforcements are in the fields of:**

- **Residential and industrial building:** restoration and strengthening of reinforced concrete, masonry and wood structures for compliance with current regulations (increase of working loads) and restoration of degraded elements;
- **Seismic retrofitting:** increased resistance and ductility of reinforced concrete structures, realization of interconnections between load-bearing walls, wrappings and bracing of the buildings, according to the provisions of the Technical Building Regulations (Ministerial Decree 14-01-2008);
- **bridges and viaducts:** flexural and shear strengthening of beams and bridge supports for functional renovation and/or adaptation to a new category. Reference regulations: CNR Technical Document 200 R1/2013, version of 15/05/2014.

The addition of FRP also substantially changes the stress state of the structure on which it is applied, so it is important to emphasize that **the FRP materials are, to all intents and purposes, structural elements and therefore must be sized and checked by a qualified technician** (usually an engineer, preferably a structural engineer).

## ANALYTICAL FRAMEWORK OF STRUCTURAL REINFORCEMENT:

The complete guide to structural reinforcement using composite materials for designers

The purpose of this booklet is to supply designers with a easy-to-use tool for an introduction to the FRP technology. The main reinforcement problems and the relative solutions that make using this technology particularly advantageous have therefore been analysed and catalogued in the form of data sheets. The data sheets have been divided into 3 categories according to the substrate material: reinforced concrete, masonry and wood. Following are the item specifications and brief descriptions of the products used.



# STRUCTURES

This chapter describes the main and most recurring problems of reinforced concrete structures. The interventions described can aim to restore the structure to the conditions existing before degradation, or they can be real strengthening interventions determined by change of use requirements or by the need to comply with new regulations.

FOLLOWING ARE THE SYNTHETIC DESCRIPTIONS OF MAIN REINFORCEMENT APPLICATIONS OF REINFORCED CONCRETE AND PRE-STRESSED REINFORCED CONCRETE STRUCTURAL ELEMENTS.

### 1) FLEXURAL STRENGTHENING • Ref. data sheet 1.1 - 1.2

The flexural strengthening with FRP composite materials is performed by applying one or more plates or one or more layers of fabric to the tense flap of the element to be reinforced. Plates are usually preferable to fabrics because they guarantee a larger resistant area with a lesser amount of material by engaging the same surface, also thanks to a safety factor higher than that of the fabrics. Generally, plates are particularly suitable for reinforced concrete and pre-stressed reinforced concrete beams and load-bearing slabs. The table below shows the diagram of a beam on two supports strengthened at the intrados where the moment is positive.

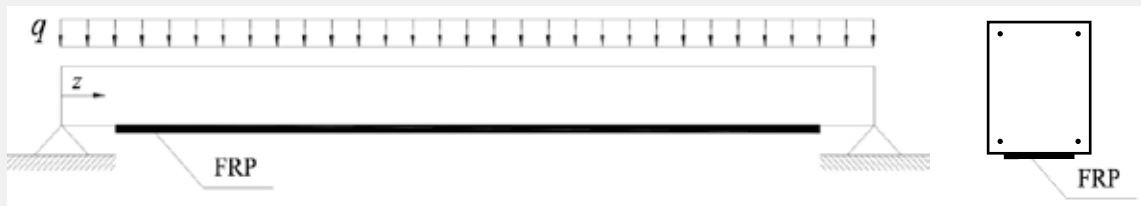

### 2) SHEAR STRENGTHENING • Ref. data sheet 1.3

Shear strengthening with composite materials is carried out by applying strips of fabric perfectly bonded to the external surface of the element to be reinforced on one or more layers. Strips may be applied discontinuously, with gaps between consecutive strips, or continuously, with strips applied next to each other. In this latter case the reinforcement appears as a sheet. Application can be performed as shown in the illustration below.

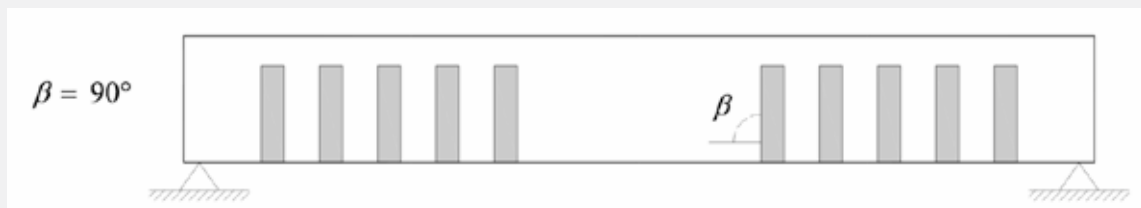

The application of fibres to the section borders may be carried out using one of the following methods:

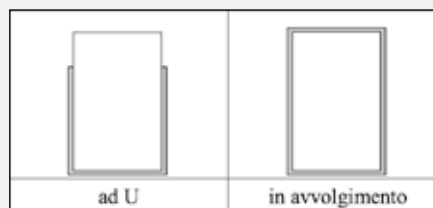



### 3) PRE-TENSIONING • Ref. data sheet 1.4

The pre-tensioning of carbon fibre plates proves to be a possible solution for structures and works such as bridges, viaducts and load-bearing slabs subject to high stress, as the plates' reduced resistant area may satisfy high load requirements, resulting in an overall technical-economic improvement in the carbon efficient use.

The beams reinforced with this technology show a considerable increase in flexural strength and a decrease of the deflection at centre, with a resulting increase in stiffness, strong ductility improvement, and a more general and considerable improvement during operation. Following are some pictures of application phases.



### 4) CONFINEMENT OF PILLARS • Ref. data sheet 1.6 - 1.7

The confinement of reinforced concrete elements can be performed using with FRP fabrics wrapped around the perimeter of the pillar so as to form a continuous or discontinuous external wrapping. It allows to increase the ultimate resistance of the elements stressed by normal centred effort or with small eccentricity.

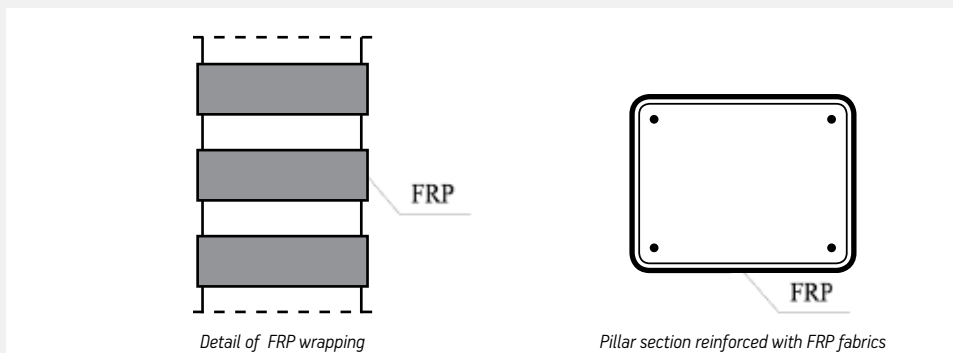

*The information given in this sheet can not disregard the proper preparation of the substrate, in order to obtain the best bonding surface and the maximum durability of the work performed, by removing all possible causes of degradation of the structure concerned.*

# REINFORCED CONCRETE BEAM

## 1.1

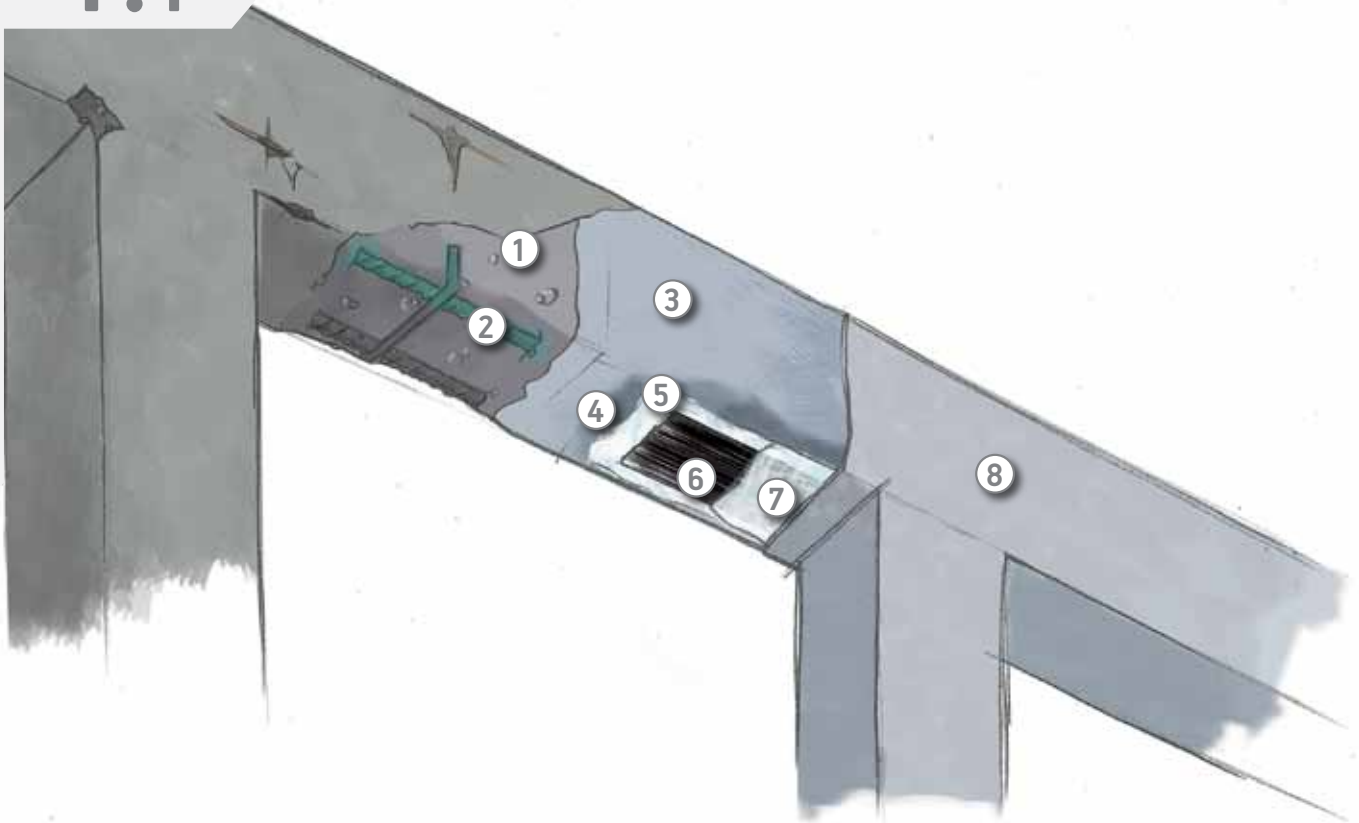

**THE PROBLEM** The beam has deficiencies in longitudinal flexural reinforcement caused by a change in load conditions or by a degradation of the initial performances of the materials.

**THE SOLUTION** The longitudinal reinforcement may be supplemented by the use of unidirectional carbon fibre fabrics, with fibres placed parallel to the axis of the beam, and directly bonded to the restored intrados of the beam itself.

**PREPARATION** Before applying the composite reinforcement, the concrete substrate must be restored. All loose and crumbling parts must be removed until the reinforcement bar is exposed. This must be treated with a passivating product DRACOSTEEL. The concrete section should be then rebuilt by means of a suitable fibre-reinforced structural mortar FLUECO 40T, two-component as appropriate FLUECO 80 T2.

**REINFORCEMENT APPLICATION:**  
To prepare the substrate, a coat of the primer Armoprimer 100 should be applied by brush on the rebuilt and restored concrete section and within 2 hours **ARMOFIX MTX**, the adhesive for the bonding of carbon fibre fabrics, will be spread. Over this, **ARMOSHIELD C-SHEET** unidirectional carbon fibre tape will be applied. The tape must be properly rolled with **ARMOROLLER** spiked metal roller to remove air bubbles that may have formed and to promote adhesive penetration into the fibres for their first impregnation. The final impregnation will be performed by using the same adhesive **ARMOFIX MTX** applied on the fibre, which will be then rolled again with the metal roller. Check that all the fibres of the fabric are perfectly impregnated. For any subsequent coat, lay the fabric over the adhesive while it is still fresh and proceed with the impregnation as described above. In order to allow the plaster to grip, sprinkle the last coat with quartz sand while the impregnating adhesive is still fresh.

**ITEM SPECIFICATIONS**

- Substrate preparation	4.0.1	page 62
- Item specifications Fabrics	4.1	page 64

# FLEXURAL STRENGTHENING WITH CARBON FIBRE FABRIC

## LEGEND

- 1 Removal of deteriorated concrete and reinforcement bars cleaning
- 2 Treatment of reinforcement bars with DRACOSTEEL
- 3 Rebuilding of the section with FLUECO fibre reinforced mortar
- 4 Application of ARMOPRIMER 100 primer
- 5 Laying of ARMOFIX MTX epoxy resin
- 6 ARMOSHIELD C-SHEET unidirectional carbon fabric
- 7 Impregnation with ARMOFIX MTX epoxy resin
- 8 Protective skim coat mortar or plaster



## DID YOU KNOW THAT...

*Heavy weight fabrics are difficult to impregnate: for a better application and a safer result, sometimes it is better to lay more coats with a lower weight.*



## FROM THE CONSTRUCTION SITE: APPLICATION IMAGES



Application of ARMOSHIELD-C carbon fibre fabrics to the intrados of the beam



Protective finishing with plaster or with other cement or resin coatings



### Reference legislation for reinforcement sizing: CNR DT 200 R1/2013 REV. 15/05/2014

Delamination test	chap. 4.1.2 - 4.1.3 - 4.1.4
Design flexural strength of the element reinforced with FRP	chap. 4.2.2.3
Combined bending and axial load strengthening	chap. 4.2.2.4
Service Limit State (SLS) Check	chap. 4.2.3.2

DOWNLOAD THE STANDARD: [http://www.cnr.it/sitocnr/IICNR/Attivita/NormazioneeCertificazione/DT200\\_R1.html](http://www.cnr.it/sitocnr/IICNR/Attivita/NormazioneeCertificazione/DT200_R1.html)

# REINFORCED CONCRETE BEAM

## 1.2

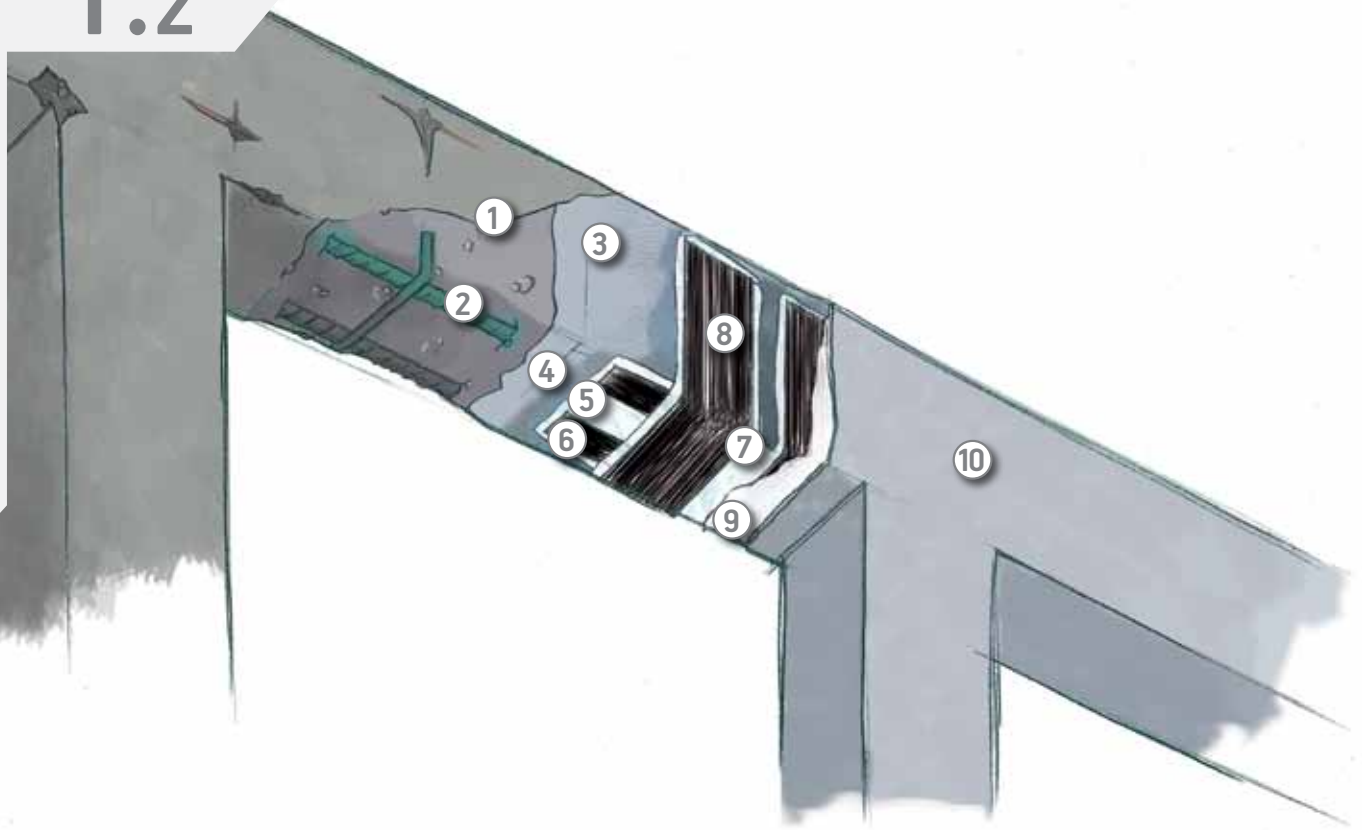

**THE PROBLEM** The beam has deficiencies in longitudinal flexural reinforcement caused by a change in load conditions or by a degradation of the initial performances of the materials.

**THE SOLUTION** The longitudinal reinforcement may be supplemented by the use of pultruded carbon fibre plates, with fibres placed parallel to the axis of the beam, and directly bonded to the restored intrados of the beam itself. This intervention is particularly useful when the reinforcement quantity becomes substantial, and when the concrete surface is already very smooth (precast beams).

**PREPARATION** Before applying the composite reinforcement, the concrete substrate must be restored. All loose and crumbling parts must be removed until the reinforcement bar is exposed. This must be treated with a passivating product DRACOSTEEL. The concrete section should be then rebuilt by means of a suitable fibre-reinforced structural mortar FLUECO 40T, two-component as appropriate FLUECO 80 T2. Millimetric restoration coats may be performed by skimming directly using ARMOFIX MTL.

**REINFORCEMENT APPLICATION** To prepare the substrate, a coat of the primer Armoprimer 100 should be applied by brush on the rebuilt and restored concrete section and within 2 hours **ARMOFIX MTX**, the adhesive for the bonding of carbon fibre fabrics, will be spread. Over this, the plate **ARMOSHIELD CFK**, cut to the size needed, will be applied. The plate must be properly rolled with a hard rubber roller to remove air bubbles that may have formed. The plate must be previously cleaned with the suitable solvent **ARMOCLEANER** on both faces in order to remove all processing residues. For any subsequent coats, lay an additional coat of **ARMOFIX MTL** over the plate previously laid, then lay the second coat taking care to roll well to remove any air bubbles. For any subsequent coats, lay an additional coat of Armofix MTL over the plate previously laid, then lay the second coat taking care to roll well to remove any air bubbles. To improve plates anchoring, provide transverse wraps in a 'U' shape by applying ARMOSHIELD-C fabrics impregnated with ARMOFIX MTX epoxy resin. In order to allow the subsequent plaster application, lay a thin coat of adhesive and sprinkle the last coat with quartz sand while the adhesive is still fresh.

**ITEM SPECIFICATIONS**

- Substrate preparation	4.0.1	page 62
- Item specifications Plates	4.2	page 68

# FLEXURAL STRENGTHENING WITH CARBON FIBRE PLATES

## LEGEND

- 1 Removal of deteriorated concrete and reinforcement bars cleaning
- 2 Treatment of reinforcement bars with DRACOSTEEL
- 3 Rebuilding of the section with FLUECO fibre reinforced mortar
- 4 Application of ARMOPRIMER 100 primer
- 5 Laying of ARMOFIX MTL epoxy adhesive
- 6 Flexural strengthening with ARMOSHIELD CFK carbon fibre plates
- 7 Laying of ARMOFIX MTL epoxy resin
- 8 ARMOSHIELD C-SHEET unidirectional carbon fabric
- 9 Impregnation with ARMOFIX MTX epoxy resin
- 10 Protective skim coat mortar or plaster

**DID YOU KNOW THAT...**  
*To improve plates anchoring, it's always useful to provide transverse U-wraps by applying the fabric continuously in a 'U' shape around the sides and bottom (tension) face of the beam.*



## FROM THE CONSTRUCTION SITE: APPLICATION IMAGES

### STEP 1



Lay the epoxy primer ARMOPRIMER 100 by brush to promote adhesion

### STEP 2



Apply the epoxy adhesive ARMOFIX MTL, ideal for plate application.

### STEP 3



Lay ARMOSHIELD CFK plates over the fresh resin coat

### STEP 4



Apply ARMOFIX MTX adhesive over the plates until they are completely covered.



### Reference legislation for reinforcement sizing: CNR DT 200 R1/2013 REV. 15/05/2014

Delamination test	chap. 4.1.2 - 4.1.3 - 4.1.4
Design flexural strength of the element reinforced with FRP	chap. 4.2.2.3
Combined bending and axial load strengthening	chap. 4.2.2.4
Service Limit State (SLS) Check	chap. 4.2.3.2

DOWNLOAD THE STANDARD: [http://www.cnr.it/sitocnr/IICNR/Attivita/NormazioneeCertificazione/DT200\\_R1.html](http://www.cnr.it/sitocnr/IICNR/Attivita/NormazioneeCertificazione/DT200_R1.html)

# REINFORCED CONCRETE BEAM

## 1.3

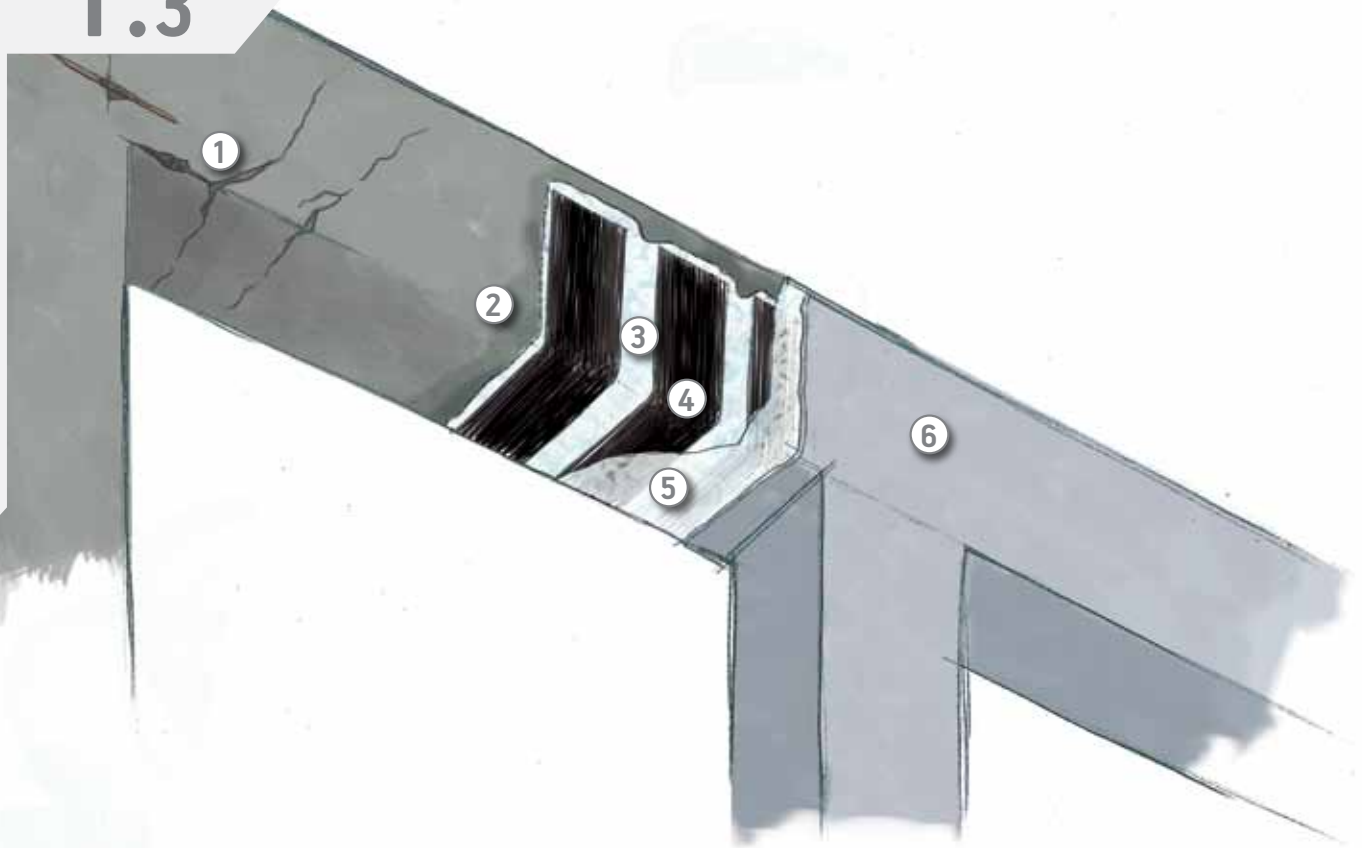

**THE PROBLEM** The beam has deficiencies in shear reinforcement (stirrups) caused by a change in load conditions or by a degradation of the initial performances of the materials.

**THE SOLUTION** The beam stirrups may be supplemented by the use of unidirectional carbon fibre fabrics, with fibres placed perpendicular to the axis of the beam and directly bonded to the beam itself, in a 'U' shape or by applying them around the entire perimeter of the beam.

**PREPARATION** Before applying the composite reinforcement, the concrete substrate must be restored. All loose and crumbling parts must be removed until the reinforcement bar is exposed. This must be treated with a passivating product DRACOSTEEL. The concrete section should be then rebuilt by means of a suitable fibre-reinforced structural mortar FLUECO 40T, two-component as appropriate FLUECO 80 T2, taking care to round the corners to a radius of curvature of at least 20 mm.

**REINFORCEMENT APPLICATION**  
To prepare the substrate, a coat of the primer **ARMOPRIMER 100** should be applied by brush on the rebuilt and restored concrete section and within 2 hours **ARMOFIX MTX**, the adhesive for the bonding of carbon fibre fabrics, will be spread. Over this, the unidirectional carbon fibre tape **ARMOSHIELD C-SHEET** will be applied. The tape must be properly rolled with **ARMOROLLER** spiked metal roller to remove air bubbles that may have formed and to promote adhesive penetration into the fibres for their first impregnation. The final impregnation will be performed by using the same adhesive **ARMOFIX MTX** applied on the fibre, which will be then rolled again with the metal roller. Check that all the fibres of the fabric are perfectly impregnated. For any subsequent coat, lay the fabric over the adhesive while it is still fresh and proceed with the impregnation as described above. In order to allow the plaster to grip, sprinkle the last coat with quartz sand while the impregnating adhesive is still fresh.

**ITEM SPECIFICATIONS**

- Substrate preparation 4.0.1 page 62
- Item specifications Fabrics 4.1 page 64

# SHEAR STRENGTHENING WITH CARBON FIBRE FABRIC

## LEGEND

- 1 Cracking due to a lack of shear reinforcement and degradation
- 2 Application of ARMOPRIMER 100 primer
- 3 Laying of ARMOFIX MTL epoxy resin
- 4 Unidirectional carbon fabric for shear strengthening ARMOSHIELD C-SHEET
- 5 Impregnation with ARMOFIX MTX epoxy resin and sprinkle of quartz sand
- 6 Protective skim coat mortar or plaster

**DID YOU KNOW THAT...**

*Edge rounding not only improves the laying and prevents the fibres to break, but also improves the intervention effectiveness.*

## FROM THE CONSTRUCTION SITE: APPLICATION IMAGES



Removal of the existing coating and surface cleaning

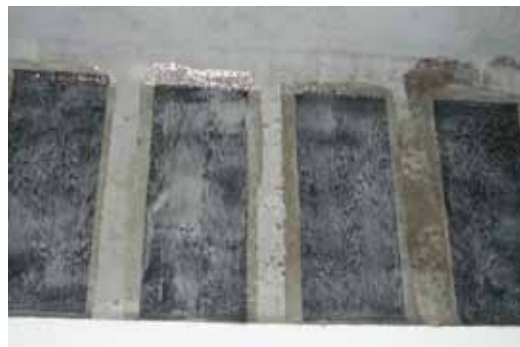

Application of ARMOSHIELD C-SHEET fabrics over the fresh coat of ARMOFIX MTX resin



Overview - Fabrics are applied close to supports



Application of protective coat



**Reference legislation for reinforcement sizing:** CNR DT 200 R1/2013 REV. 15/05/2014

Delamination test	chap. 4.1.2 - 4.1.3 - 4.1.4
Shear strengthening	chap. 4.3.3

DOWNLOAD THE STANDARD: [http://www.cnr.it/sitocnr/IICNR/Attivita/NormazioneeCertificazione/DT200\\_R1.html](http://www.cnr.it/sitocnr/IICNR/Attivita/NormazioneeCertificazione/DT200_R1.html)

# REINFORCED CONCRETE BEAM

1.4

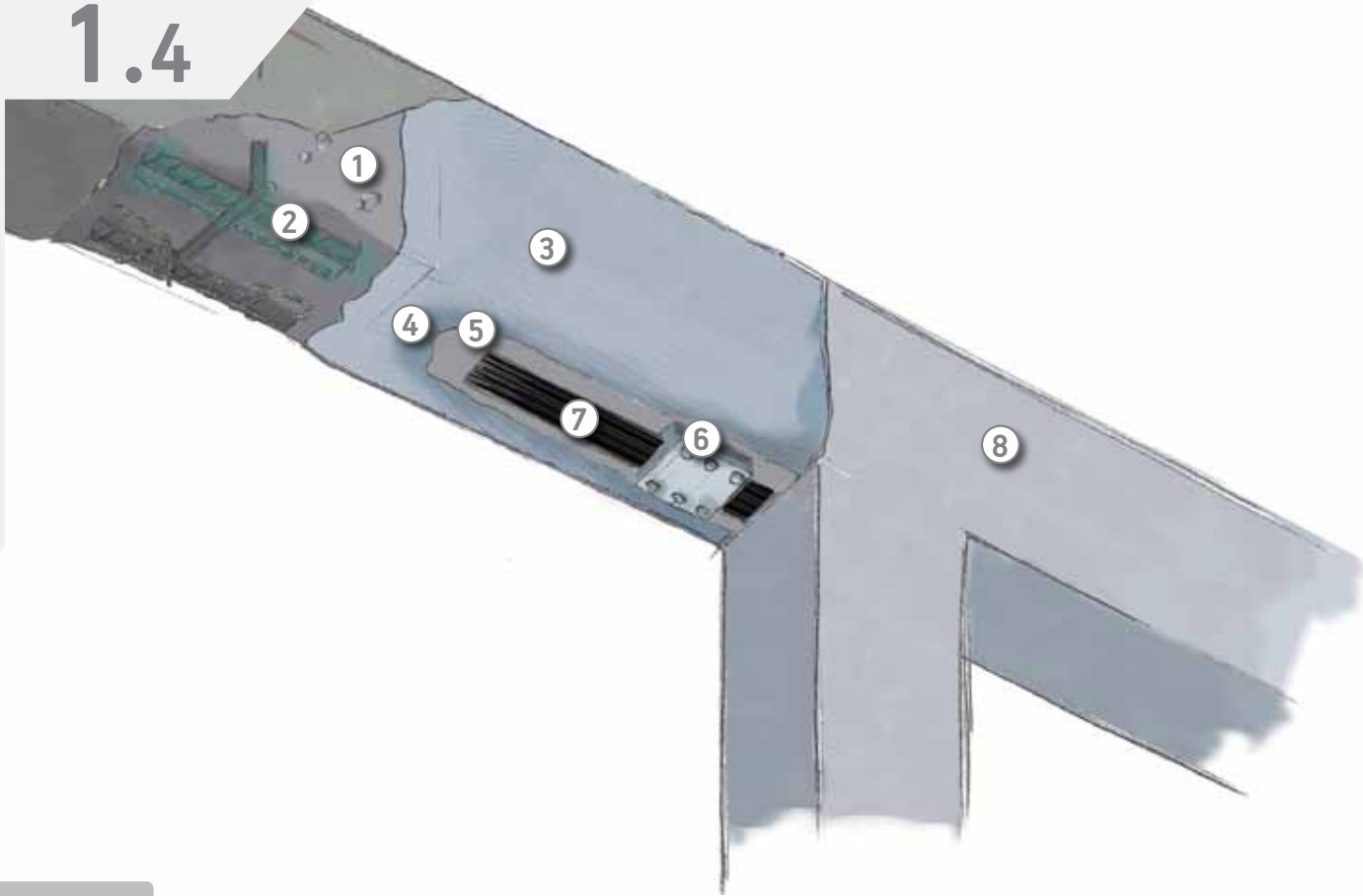

**THE PROBLEM** Degradation and deterioration of the beam caused by a change in load conditions or by a degradation of the initial performances of the materials with consequent reduction of the load-bearing capacity, resulting in the shearing off of some pre-stressing strands and in concrete detachment.

**THE SOLUTION** To reinforce the intrados of the beam by using pultruded carbon fibre plates appropriately pre-tensioned, in order to provide the beam with the same pre-compression which it lost as a result of the strands cutting off.

**PREPARATION** All loose and crumbling parts must be removed until the reinforcement bar is exposed. This must be treated with a passivating product DRACOSTEEL. The concrete section should be then rebuilt by means of a suitable fibre-reinforced structural mortar FLUECO 40T, two-component FLUECO 80 T2 in case of weak supports and ground surfaces. For sections thicker than 3-4 cm use the fibre reinforced mortar FLUECO 175 T CR FR. The holes should be then drilled in order to allow the insertion of steel fixing anchors, and anchor plates and wedge plates should be prepared.

**REINFORCEMENT APPLICATION**  
To prepare the substrate, a coat of **ARMOPRIMER 100** primer should be applied by brush on the rebuilt and dedusted concrete section. **ARMOSHIELD CFK** plate, cut to the size needed and cleaned on both faces with suitable solvent, should be placed on the fixed side and fixed to the anchor plate by resin and anchors properly tightened; later, the wedge plates should be fixed in order to anchor the plate and resist during tensioning. The plate should be laid along the entire length of the beam and bonded by using the specific bonding adhesive **ARMOFIX MTL**. The movable wedge plates and the hydraulic jack should be positioned, the project tension load should be applied, and then the jack should be mechanically blocked. Finally, the plate should be rolled with a hard rubber roller to ensure adhesion to the substrate. After about 24 hours from the plate laying, the jack and the wedge plates may be removed from both sides of the beam. In order to allow the subsequent plaster application, lay a thin coat of adhesive and sprinkle the last coat with quartz sand while the adhesive is still fresh.

**ITEM SPECIFICATIONS**

- Substrate preparation	4.0.1	page 62
- Item specifications Pre-tensioning	4.8	page 82



# FLEXURAL STRENGTHENING AND COMPRESSION RESTORING THROUGH PRE-TENSIONING OF CARBON PLATES

## LEGEND

- 1 Removal of deteriorated concrete and reinforcement bars cleaning
- 2 Treatment of reinforcement bars with DRACOSTEEL
- 3 Rebuilding of the section with FLUECO fibre reinforced mortar
- 4 Application of ARMOPRIMER 100 primer
- 5 Laying of ARMOFIX MTL epoxy resin
- 6 Plate application
- 7 Plate insertion, anchoring of one head and subsequent plate tensioning
- 8 Protective skim coat mortar or plaster

**DID YOU KNOW THAT...**  
*The plate stress/strain ratio is linear up to failure, therefore, if you want to find the stress to which it is pre-tensioned, simply measure its elongation.*

## FROM THE CONSTRUCTION SITE: APPLICATION IMAGES

**STEP 1**



*Drilling of the holes for plate anchoring and application of ARMOPRIMER 100 primer*

**STEP 2**



*Plate anchoring*

**STEP 3**



*Application of ARMOSHIELD CFK plate along the length of the beam*

**STEP 4**



*Plate pre-tensioning with hydraulic jack*



**Reference legislation for reinforcement sizing:** CNR DT 200 R1/2013 REV. 15/05/2014

Delamination test	chap. 4.1.2 - 4.1.3 - 4.1.4
Flexural strengthening	chap. 4.2.2.3 - chap. 4.6.1.1 for pre-stressed elements
Combined bending and axial load strengthening	chap. 4.2.2.4
Service Limit State (SLS) Check	chap. 4.2.3.2 - chap. 4.6.1.2 for pre-stressed elements

DOWNLOAD THE STANDARD: [http://www.cnr.it/sitocnr/IICNR/Attivita/NormazioneeCertificazione/DT200\\_R1.html](http://www.cnr.it/sitocnr/IICNR/Attivita/NormazioneeCertificazione/DT200_R1.html)

# FLOOR SLAB IN BRICK-CEMENT

## 1.5

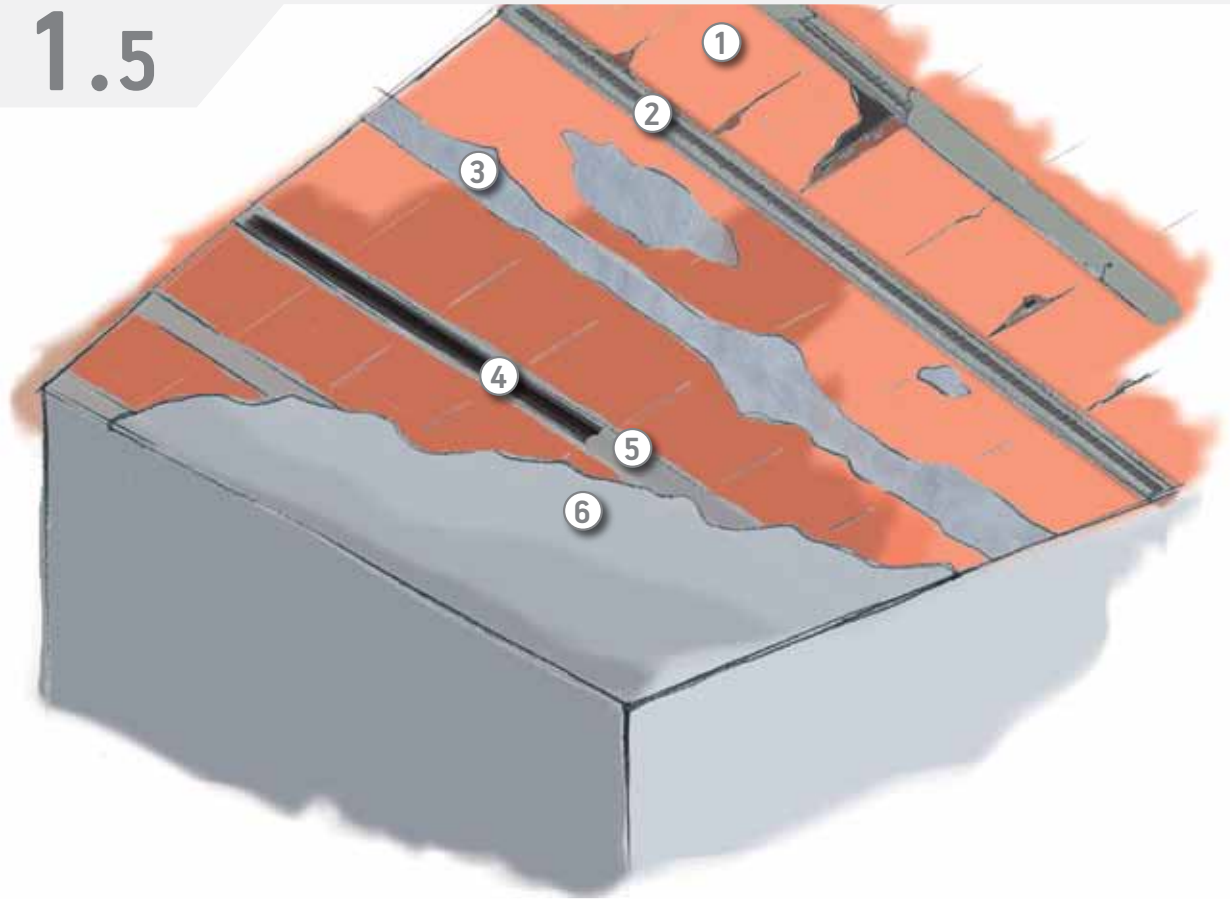

**THE PROBLEM** The floor slab has deficiencies in longitudinal reinforcement caused by a change in load conditions or by a degradation of the initial performances of the material (degradation caused by moisture, fire, etc.).

**THE SOLUTION** The longitudinal reinforcement may be supplemented by the use of pultruded carbon fibre plates, with fibres placed parallel to the axis of the joist, and directly bonded to the restored intrados of each joist making up the floor slab. This operation requires the demolition of the brick bottom of the joist, because the reinforcement needs to be anchored directly to the resistant element.

**PREPARATION** The degraded elements of the floor slab must first be removed. The brick bottom of the joist must be removed until the reinforcement bar is exposed. This must be treated with a passivating product DRACOSTEEL. The joist concrete section and the bottom should be then rebuilt by means of a suitable fibre-reinforced structural mortar FLUECO 40T, two-component as appropriate FLUECO 80 T2.

**REINFORCEMENT APPLICATION**  
To prepare the substrate, a coat of the primer **ARMOPRIMER 100** should be applied by brush on the rebuilt and restored concrete section and within 2 hours **ARMOFIX MTL**, the adhesive for the bonding of carbon fibre plates, will be spread. Over this, the plate **ARMOSHIELD CFK**, cut to the size needed, will be applied. The plate must be properly rolled to remove air bubbles that may have formed. The plate must be previously cleaned with the suitable solvent **ARMOCLEANER** on both faces in order to remove all processing residues. For any subsequent coats, lay an additional coat of **ARMOFIX MTL** over the plate previously laid, then lay the second coat taking care to roll well to remove any air bubbles. In order to allow the subsequent plaster application, lay a thin coat of adhesive and sprinkle the last coat with quartz sand while the adhesive is still fresh.

**ITEM SPECIFICATIONS**

- Substrate preparation	4.0.1	page 62
- Item specifications Plates	4.2	page 68

# FLEXURAL STRENGTHENING WITH CARBON FIBRE PLATES

## LEGEND

- 1 Degraded floor-slab
- 2 Demolition of the joist bottom and passivating treatment of reinforcement bars with DRACOSTEEL
- 3 Joist rebuilding with FLUECO fibre reinforced mortar
- 4 Carbon fibre plates bonding
- 5 Laying of ARMOFIX MTL epoxy adhesive
- 6 Finishing with plaster

**DID YOU KNOW THAT...**

*You can reduce fragile collapse mechanisms of brick elements with the anti-collapse system (sheet 1.10 page 28).*

## FROM THE CONSTRUCTION SITE: APPLICATION IMAGES



Demolition of the joist bottom and surface cleaning



Application of ARMOFIX MTL epoxy resin, ideal for plate bonding

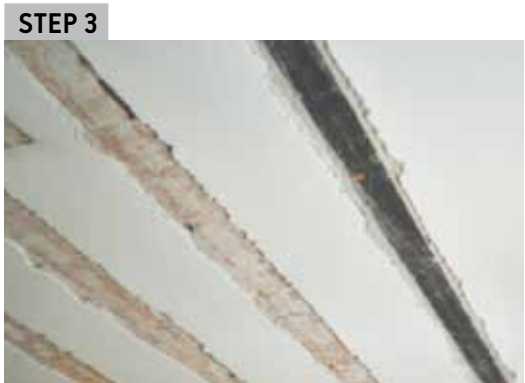

Application of ARMOSHIELD CFK plates over the fresh resin coat



**Reference legislation for reinforcement sizing:** CNR DT 200 R1/2013 REV. 15/05/2014

Delamination test	chap. 4.1.2 - 4.1.3 - 4.1.4
Design flexural strength of the element reinforced with FRP	chap. 4.2.2.3
Combined bending and axial load strengthening	chap. 4.2.2.4
Service Limit State (SLS) Check	chap. 4.2.3.2

DOWNLOAD THE STANDARD: [http://www.cnr.it/sitocnr/IICNR/Attivita/NormazioneeCertificazione/DT200\\_R1.html](http://www.cnr.it/sitocnr/IICNR/Attivita/NormazioneeCertificazione/DT200_R1.html)

# REINFORCED CONCRETE PILLAR

## 1.6

### ? THE PROBLEM

The concrete strength of the compressed pillar is below expectations, or there is a need to increase concrete compressive strength in order to improve section ductility.

### 👍 THE SOLUTION

By wrapping the pillar with unidirectional fabric, compressive strength of concrete can be improved. The increase in compressive strength can be obtained depending on section geometry, on source material and on the arrangement of the wraps applied around the entire perimeter, and it also leads to an increase in the ultimate compressive strain of concrete, in other words it increases its ductility.

### ● PREPARATION

Before applying the composite reinforcement, the concrete substrate must be restored. All loose and crumbling parts must be removed until the reinforcement bar is exposed. This must be treated with a passivating product DRACOSTEEL. The concrete section should be then rebuilt by means of a suitable fibre-reinforced structural mortar FLUECO 40T, two-component as appropriate FLUECO 80 T2. The pillar edges should be rounded to a radius of curvature of at least 20 mm.

### ✔ REINFORCEMENT APPLICATION

To prepare the substrate, a coat of the primer **ARMOPRIMER 100** should be applied by brush on the rebuilt and restored concrete section and within 2 hours **ARMOFIX MTX**, the adhesive for the bonding of carbon fibre fabrics, will be spread. Over this, the unidirectional carbon fibre fabric **ARMOSHIELD CFK**, cut to the size needed, will be applied, with an overlapping of at least 20 cm orientated in the direction of fibres. The laid fabric should be properly rolled with a spiked metal roller **ARMOROLLER** to remove air bubbles that may have formed and to promote fibres impregnation. An additional coat of **ARMOFIX MTX** will be then laid on the fabric in order to complete impregnation, always by rolling. For any subsequent coats, lay an additional coat of **ARMOFIX MTX** over the fabric previously laid, then lay the second coat taking care to roll well to remove any air bubbles and perfectly impregnate the fibres. In order to allow the subsequent plaster or other cement/resin protective application, just sprinkle the last coat with quartz sand while the adhesive is still fresh.

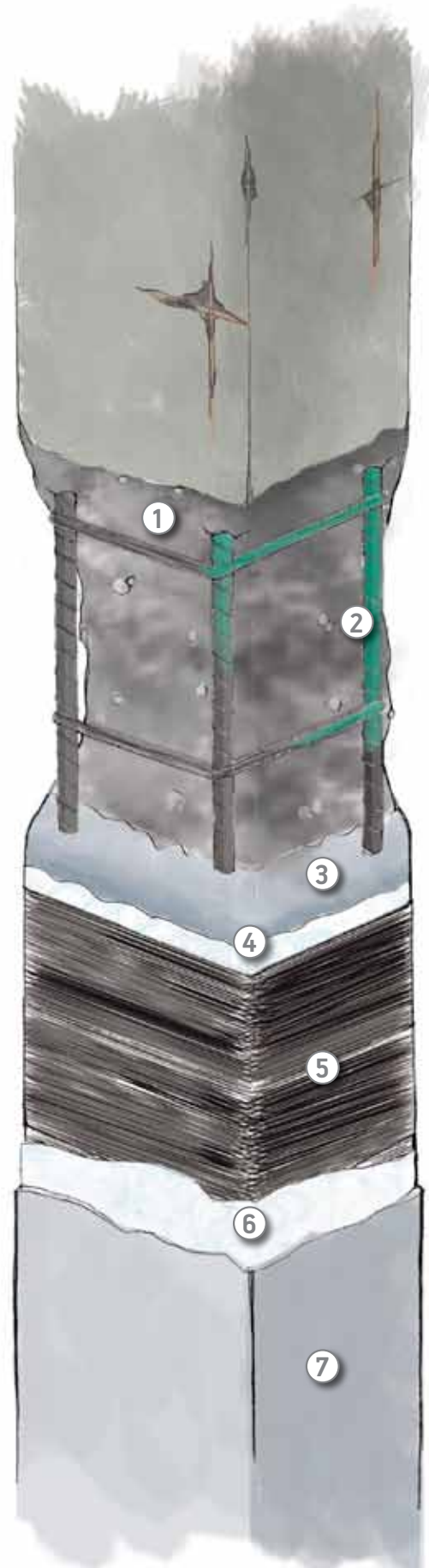

### ▶ ITEM SPECIFICATIONS

- Substrate preparation 4.0.1 page 62
- Item specifications Fabrics 4.1 page 64

# COMPRESSIVE STRENGTHENING THROUGH CONFINEMENT WITH CARBON FIBRE FABRICS

## LEGEND

- 1 Removal of deteriorated concrete and reinforcement bars cleaning
- 2 Treatment of reinforcement bars with DRACOSTEEL
- 3 Rebuilding with FLUECO fibre reinforced mortar
- 4 ARMOFIX MTX epoxy adhesive for bonding
- 5 Wrapping with ARMOSHIELD C-SHEET unidirectional fabrics
- 6 ARMOFIX MTX epoxy resin for impregnation
- 7 Finishing plaster or protective resin

**DID YOU KNOW THAT...**

*The heavier the weight of fabric used, the greater the rounding of the edges, to avoid detachments during the laying.*

## FROM THE CONSTRUCTION SITE: APPLICATION IMAGES



Volumetric rebuilding of the pillar with reinforced mortar of FLUECO line



Laying of ARMOSHIELD C-SHEET fabric and impregnation with ARMOFIX MTX epoxy resin



Overview - Reinforced concrete pillars with ARMOSHIELD C-SHEET carbon fibre fabric



**Reference legislation for reinforcement sizing:** CNR DT 200 R1/2013 REV. 15/05/2014

- |  |             |
|--|-------------|
| Centred design compressive strength or with small eccentricity of the confined element                         | chap. 4.5.2 |
| Ductility of elements subjected to compression and combined bending and axial load confined with FRP materials | chap. 4.5.3 |

DOWNLOAD THE STANDARD: [http://www.cnr.it/sitocnr/IICNR/Attivita/NormazioneeCertificazione/DT200\\_R1.html](http://www.cnr.it/sitocnr/IICNR/Attivita/NormazioneeCertificazione/DT200_R1.html)

# REINFORCED CONCRETE PILLAR

## 1.7

### ? THE PROBLEM

The pillar has deficiencies in longitudinal reinforcement and shear stirrups, and needs to achieve a higher compressive load-bearing capacity.

### 👍 THE SOLUTION

The longitudinal reinforcement may be supplemented by the use of pultruded carbon fibre plates, with fibres placed parallel to the axis of the pillar and properly anchored at the junctions by aramid connectors, while shear and compressive strength can be increased by wrapping the pillar with unidirectional fibres centre spaced or applied around the entire perimeter of the pillar.

### ● PREPARATION

All loose and crumbling parts must be removed until the reinforcement bar is exposed. This must be treated with a passivating product DRACOSTEEL. The concrete section should be then rebuilt by means of a suitable fibre-reinforced structural mortar FLUECO 40T, two-component as appropriate FLUECO 80 T2. The edges should be rounded to a radius of curvature of at least 20 mm.

### ✔ REINFORCEMENT APPLICATION

To prepare the substrate, a coat of the primer **ARMOPRIMER 100** should be applied by brush on the rebuilt and restored concrete section and within 2 hours **ARMOFIX MTL**, the adhesive for the bonding of carbon fibre plates, will be spread. Over this, the plates **ARMOSHIELD CFK** will be applied and pressed by hand or by hard rubber roller to remove air bubbles that may have formed. The plates must be previously cleaned with the suitable **ARMOCLEANER** solvent. After the laying of the plates, the adhesive **ARMOFIX MTX** may be spread in order to smooth the surface and to lay **ARMOSHIELD C-SHEET** unidirectional fabric, which will then be impregnated with the same adhesive. For any subsequent coat, lay the fabric over the adhesive while it is still fresh and proceed with the impregnation as described above. In order to allow the plaster to grip, sprinkle with quartz sand while the adhesive is still fresh.



### ▶ ITEM SPECIFICATIONS

- Substrate preparation 4.0.1 page 62
- Item specifications Fabrics 4.1 page 64
- Item specifications Plates 4.2 page 68

# COMBINED BENDING AND AXIAL LOAD STRENGTHENING AND SHEAR STRENGTHENING WITH PLATES AND CARBON FIBRE FABRICS

## LEGEND

- 1 Removal of deteriorated concrete and reinforcement bars cleaning
- 2 Treatment of reinforcement bars with DRACOSTEEL
- 3 Rebuilding with FLUECO fibre reinforced mortar
- 4 ARMOFIX MTL laying of the epoxy adhesive
- 5 Flexural strengthening with ARMOSHIELD CFK plates
- 6 ARMOFIX MTX resin for bonding
- 7 Wrapping with ARMOSHIELD C-SHEET unidirectional fabrics
- 8 ARMOFIX MTX resin for impregnation
- 9 Finishing plaster

**DID YOU KNOW THAT...**

*You can restore micro-cracks and damaged areas by using EPOX INIEZIONE RM2.*



## FROM THE CONSTRUCTION SITE: APPLICATION IMAGES

**STEP 1**



Removal of the existing coating and surface cleaning

**STEP 2**



Application of ARMOFIX MTL epoxy adhesive for bonding and ARMOSHIELD CFK plates

**STEP 3**



Laying of ARMOSHIELD C-SHEET unidirectional fabrics on ARMOFIX MTX resin and impregnation

**STEP 4**



Complete wrapping around the entire perimeter of the pillar



**Reference legislation for reinforcement sizing:** CNR DT 200 R1/2013 REV. 15/05/2014

Combined bending and axial load strengthening	chap. 4.2.2.4
Shear strengthening	chap. 4.3.3
Centred design compressive strength or with small eccentricity of the confined element	chap. 4.5.2
Ductility of elements subjected to compression and combined bending and axial load confined with FRP materials	chap. 4.5.3

DOWNLOAD THE STANDARD: [http://www.cnr.it/sitocnr/IICNR/Attivita/NormazioneeCertificazione/DT200\\_R1.html](http://www.cnr.it/sitocnr/IICNR/Attivita/NormazioneeCertificazione/DT200_R1.html)

# BEAM-PILLAR JUNCTION

1.8

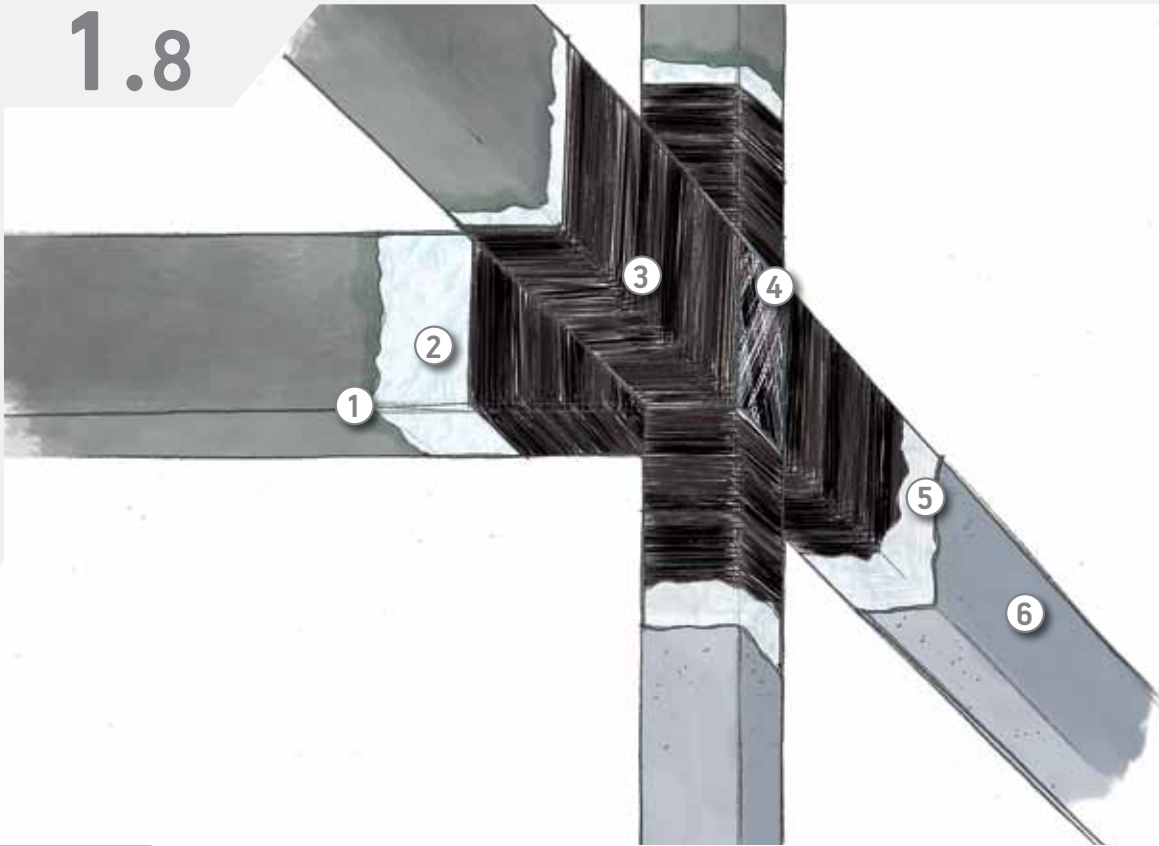

**? THE PROBLEM** There is a need to increase the shear strength of the beam and pillar in the point of convergence, in order to restore the proper strength hierarchy between the elements.

**👍 THE SOLUTION** By shear wrapping the beam and by wrapping the pillar around its entire perimeter with unidirectional fabric, you can increase the shear strength of the beam and pillar as well as the concrete ductility of the pillar. This would also improve the dissipation capacity of the intersection under seismic action. To reinforce the junction panel it is good practice to bond a quadriaxial fabric sheet ARMOSHIELD C-QUADRAX, by extending it on the webs of the beam and pillar and by turning it up.

**🕒 PREPARATION** Before applying the composite reinforcement, the concrete substrate must be restored. All loose and crumbling parts must be removed until the reinforcement bar is exposed. This must be treated with a passivating product DRACOSTEEL. The concrete section should be then rebuilt by means of a suitable fibre-reinforced structural mortar FLUECO 40T, two-component as appropriate FLUECO 80 T2. The edges of the beam and pillar should be rounded to a radius of curvature of at least 20 mm.

**✅ REINFORCEMENT APPLICATION**  
To prepare the substrate, a coat of the primer **ARMOPRIMER 100** should be applied by brush on the rebuilt and restored concrete section and within 2 hours **ARMOFIX MTX**, the adhesive for the bonding of carbon fibre fabrics, will be spread. Over this, both the quadriaxial fabric sheet and the unidirectional carbon fibre fabric **ARMOSHIELD C-SHEET**, cut to the size needed to achieve the beam shear strengthening and the pillar wrapping, will be applied. The pillar wrapping should be fulfilled with an overlapping of at least 20 cm orientated in the direction of fibres. The laid fabric should be properly rolled by using **ARMOROLLER** to remove air bubbles that may have formed and to promote fibres impregnation. An additional coat of **ARMOFIX MTX** will be then laid on the fabric in order to complete impregnation, always by rolling. For any subsequent coats, lay an additional coat of **ARMOFIX MTX** over the fabric previously laid, then lay the second coat taking care to roll well to remove any air bubbles and perfectly impregnate the fibres. In order to allow the subsequent plaster application, sprinkle the last coat with quartz sand while the adhesive is still fresh.

**▶ ITEM SPECIFICATIONS**

- Substrate preparation	4.0.1	page 62
- Item specifications Fabrics	4.1	page 64



# JUNCTION STRENGTHENING THROUGH CONFINEMENT WITH CARBON FIBRE FABRICS



## LEGEND

- 1 Application of ARMOPRIMER 100 primer
- 2 ARMOFIX MTX resin for bonding
- 3 Wrapping with ARMOSHIELD C unidirectional or quadriaxial fabrics
- 4 Plate bonding with ARMOSHIELD C-QUARDAX quadriaxial fabrics
- 5 ARMOFIX MTX resin for impregnation
- 6 Finishing plaster



## DID YOU KNOW THAT...

*You can protect, decorate and coat your work with the elastic acrylic paint ACRIFLEX.*



## FROM THE CONSTRUCTION SITE: APPLICATION IMAGES

### STEP 1



*Beam-pillar junction before the intervention*

### STEP 2



*Wrapping of the pillar with ARMOSHIELD C carbon fibre fabrics*

### STEP 3



*Wrapping detail*

### STEP 4



*The confinement intervention has been accomplished*



**Reference legislation for reinforcement sizing:** CNR DT 200 R1/2013 REV. 15/05/2014

Shear strengthening	chap. 4.3.3
Centred design compressive strength or with small eccentricity of the confined element	chap. 4.5.2
Ductility of elements subjected to compression and combined bending and axial load confined with FRP materials	chap. 4.5.3
Increase in local deformation capacity of the elements	chap. 4.7.2.3.1

DOWNLOAD THE STANDARD: [http://www.cnr.it/sitocnr/IICNR/Attivita/NormazioneeCertificazione/DT200\\_R1.html](http://www.cnr.it/sitocnr/IICNR/Attivita/NormazioneeCertificazione/DT200_R1.html)

# REINFORCED CONCRETE WALLS

## 1.9

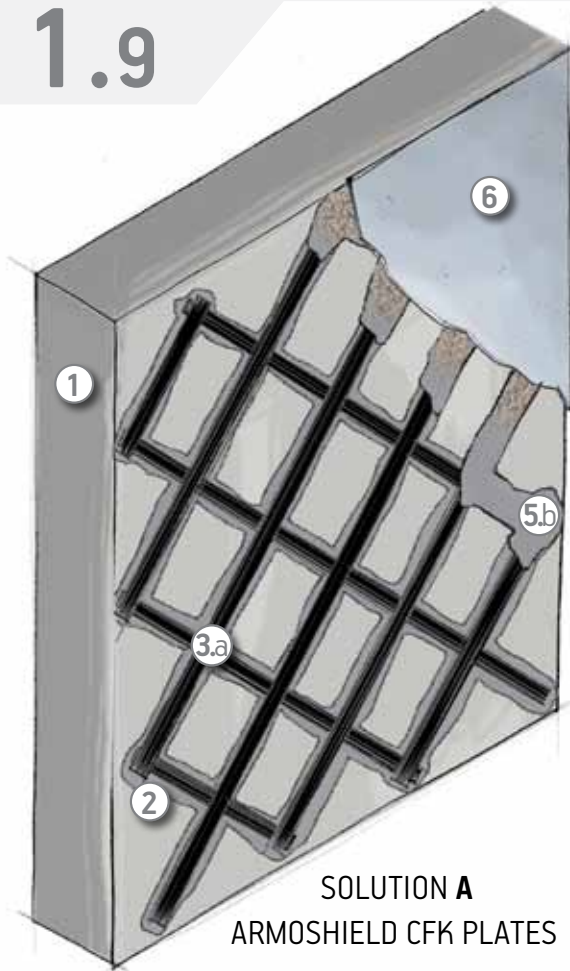

**SOLUTION A**  
ARMOSHIELD CFK PLATES

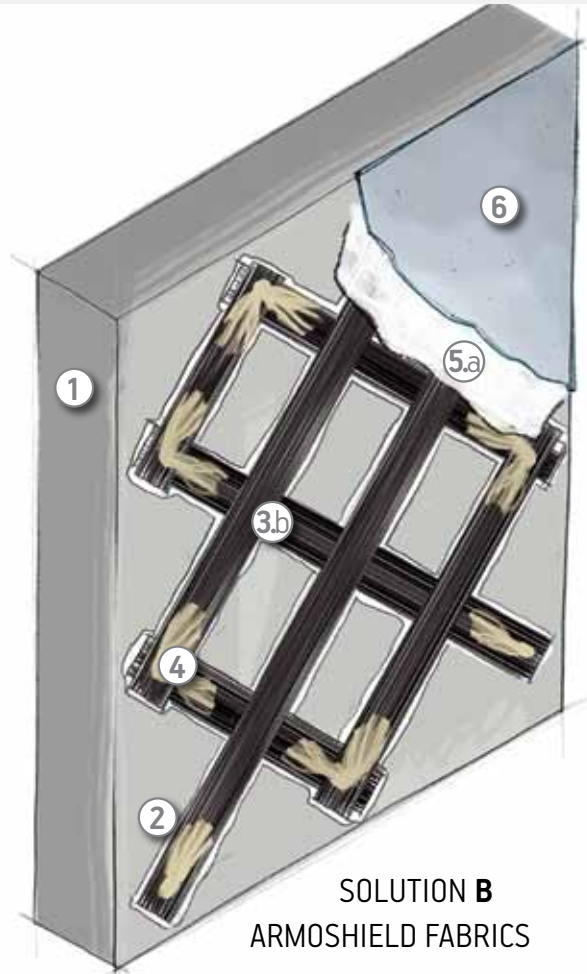

**SOLUTION B**  
ARMOSHIELD FABRICS

**THE PROBLEM** To improve the shear behaviour of reinforced concrete walls for seismic reinforcement or retrofitting as per regulation.

**THE SOLUTION** To create a diagonal-cross bracing with wraps of unidirectional carbon fibre laid on the two sides of the panel, connected together by pass-through connectors on intersections.

**PREPARATION** All loose and crumbling parts must be removed until the reinforcement bar is exposed. This must be treated with a passivating product DRACOSTEEL. The concrete section should be then rebuilt by means of a suitable fibre-reinforced structural mortar FLUECO 40T, two-component as appropriate FLUECO 80 T2.

**REINFORCEMENT APPLICATION**  
To prepare the substrate, a coat of the primer **ARMOPRIMER 100** should be applied by brush on the rebuilt and restored concrete section and within 2 hours **ARMOFIX MTX**, the adhesive for the bonding of carbon fibre fabrics, will be spread. Over this, the unidirectional carbon fibre tape **ARMOSHIELD C-SHEET** will be applied. The tape must be properly rolled with **ARMOROLLER** spiked metal roller to remove air bubbles that may have formed and to promote adhesive penetration into the fibres for their first impregnation. The final impregnation will be performed by using the same adhesive **ARMOFIX MTX** applied on the fibre, which will be then rolled again with the metal roller. Check that all the fibres of the fabric are perfectly impregnated. For any subsequent coat, lay the fabric over the adhesive while it is still fresh and proceed with the impregnation as described above. In order to allow the plaster to grip, sprinkle the last coat with quartz sand while the impregnating adhesive is still fresh.

- ITEM SPECIFICATIONS**
- Substrate preparation 4.0.1 page 62
  - Item specifications Fabrics 4.1 page 64
  - Item specifications Plates 4.2 page 68

# SHEAR STRENGTHENING WITH CARBON FIBRE FABRICS AND PLATES

## LEGEND

- 1 Reinforced concrete wall
- 2 ARMOFIX MTL resin for bonding
- 3.a Reinforcement with ARMOSHIELD CFK plates on both sides
- 3.b ARMOSHIELD C-SHEET carbon fibre fabrics on both sides of the wall
- 4 ARMOGRIP double aramid thread
- 5.a ARMOFIX MTX resin
- 5.b ARMOFIX MTL resin
- 6 Finishing plaster

**DID YOU KNOW THAT...**

*The intervention should preferably be carried out on both sides of the wall to avoid asymmetries that could induce side effects.*

## FROM THE CONSTRUCTION SITE: APPLICATION IMAGES



Braces made with ARMOSHIELD C unidirectional carbon fibre fabrics



Braces made with ARMOSHIELD CFK carbon fibre plates



**Reference legislation for reinforcement sizing:** CNR DT 200 R1/2013 REV. 15/05/2014

Delamination test

chap. 4.1.2 - 4.1.3 - 4.1.4

The calculation model is not included in the CNR document, however, it is possible to schematise the system through the strut and tie model, by checking delamination and interfacial tension.

DOWNLOAD THE STANDARD: [http://www.cnr.it/sitocnr/IICNR/Attivita/NormazioneeCertificazione/DT200\\_R1.html](http://www.cnr.it/sitocnr/IICNR/Attivita/NormazioneeCertificazione/DT200_R1.html)

# MASONRY BUFFER WALLS AND FLOOR SLABS

## 1.10

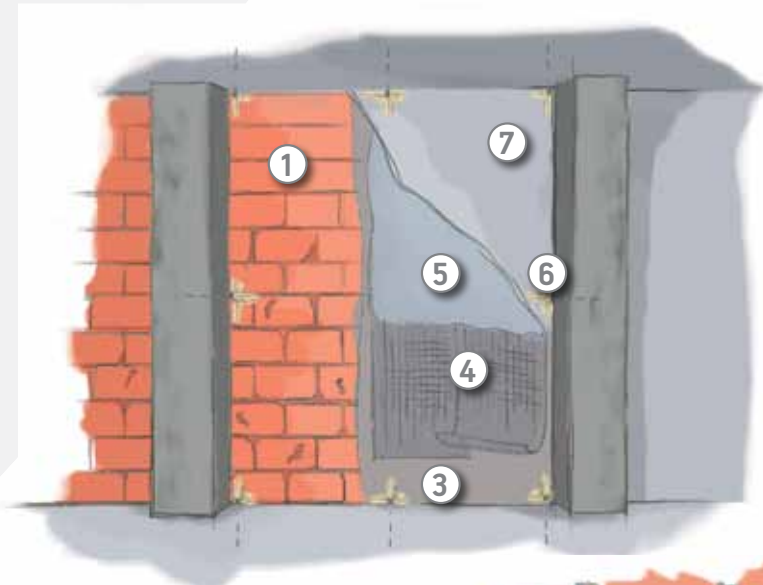

NON-STRUCTURAL PANEL

### ? THE PROBLEM

The collapse and overturning of masonry buffer walls and the collapse of fragile brick elements of the floor slab is expected.

### 👍 THE SOLUTION

To improve anti-seismic performance of masonry buffer walls and floor slabs through an anti-overturning system that prevents cracks and reduces collapse and overturning risk.

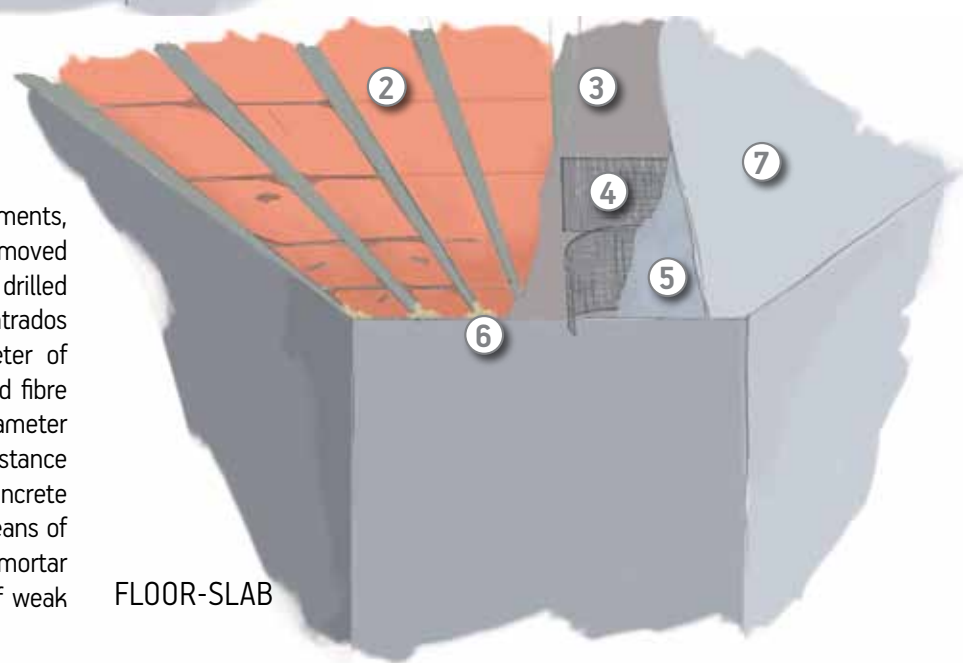

FLOOR-SLAB

### ● PREPARATION

Plaster residues, previous surface treatments, damaged and loose parts must be removed from the masonry walls. Holes should be drilled approximately every 2 metres on the intrados of the floor slab or along the perimeter of the panel in order to house the aramid fibre connectors. The holes should have a diameter of about 20 mm and a depth of 10 cm (distance from the masonry: about 1.5 cm). The concrete section should be then smoothed by means of a suitable fibre-reinforced structural mortar FLUECO 40T, two-component in case of weak supports FLUECO 80 T2.

### ✔ REINFORCEMENT APPLICATION

**Connector positioning and anchoring:** cut the connector to the length needed. Prepare **ARMOFIX MTX** resin and inject it inside the hole taking care to fill approximately half of it, insert **ARMOGRIP** connector inside the hole and proceed with the impregnation and filling of the connector cavity for its entire length with **ARMOFIX MTX**. **Reinforcement application:** on the restored masonry section, a coat of **ARMOTECH MONO** mortar should be applied to smooth the surface and provide a uniform substrate, whose average thickness should be of about 3 mm depending on the surface irregularities. The basalt fibre mesh **ARMONET B 250** cut to the size needed, should be laid on the first layer of mortar. Any cold joint should be made through simple overlap of at least 10 cm. Later, an additional coat of **ARMOTECH MONO** of about 3 mm should be laid on the mortar which has not yet hardened and on the mesh by uniformly covering it. For any subsequent layers, repeat the process always using the wet-on-wet technique. **Connector anchoring:** once the last coat of **ARMOTECH MONO** mortar has hardened, anchor the terminal part of the connector: the connector portion which has not been impregnated and comes out of the hole (thread) should be opened like a fan and fixed to the surface surrounding the hole by resin impregnation. The adhesive **ARMOFIX MTX** should be applied first on the surface to be bonded and then on the fibres opened like a fan. Cover the thread with a coat of **ARMOTECH MONO** mortar.

### ▶ ITEM SPECIFICATIONS

- Substrate preparation
- Item specifications Anti-overturning

4.0.2 page 63  
4.9 page 84

# ANTI-OVERTURNING AND ANTI-COLLAPSE REINFORCEMENT TO ENHANCE ANTI-SEISMIC PERFORMANCE



## LEGEND

- 1 Masonry buffer wall
- 2 Floor slab
- 3 First coat of ARMOTECH MONO mortar
- 4 ARMONET B 250 basalt fibre mesh
- 5 Final skimming with ARMOTECH MONO mortar
- 6 ARMOGRIP aramid connectors
- 7 Finishing plaster



## DID YOU KNOW THAT...

*In masonry buffer walls, reinforcement must be applied on both sides.*



## FROM THE CONSTRUCTION SITE: APPLICATION IMAGES



*The mesh is applied between two coats of ARMOTECH MONO mortar.*



*The anti-overturning intervention has been accomplished*

DOWNLOAD THE STANDARD: [http://www.cnr.it/sitocnr/IICNR/Attivita/NormazioneeCertificazione/DT200\\_R1.html](http://www.cnr.it/sitocnr/IICNR/Attivita/NormazioneeCertificazione/DT200_R1.html)

# STRUCTURES

This chapter concerns the main and most common issues that may arise when reinforcing masonry structures. The reinforcements applied to improve local phenomena (overturning, bending, etc.) and resistance deriving from overall assessments will be examined (i.e. flexural strengthening, shear strengthening, wrapping, etc.). We must stress the importance of an overall assessment of the building on which the intervention is to be carried out so that it can be reinforced without affecting the structure especially from a seismic point of view and operating on the stiffness and resistance of single structural elements.

WHAT FOLLOWS IS A SYNTHETIC DESCRIPTION OF THE MAIN INTERVENTIONS TO REINFORCE MASONRY:

## 1) CONFINEMENT OF PILLARS • Ref. data sheet 2.1

The confinement of masonry columns and pillars can be performed, as for the reinforced concrete elements, using FRP fabrics wrapped around the perimeter of the pillar so as to form a continuous or discontinuous external wrapping. It allows to increase the ultimate resistance of the elements stressed by normal centred effort or with small eccentricity.

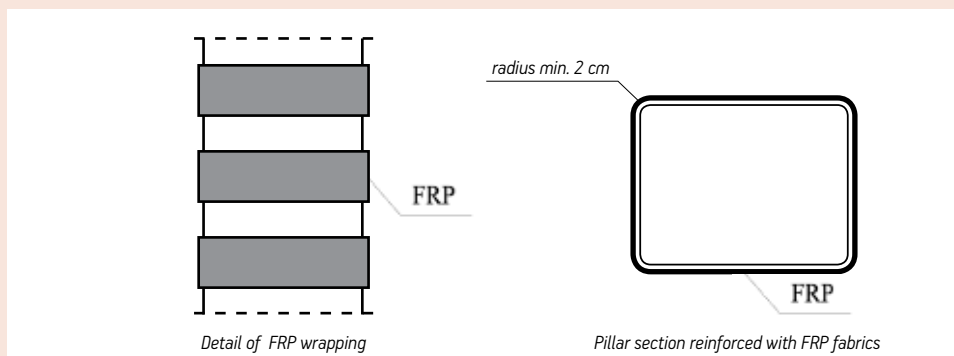

## 2) WALL PANEL

Masonry wall panels can be reinforced with FRP materials in order to increase their lift or ductility in respect of stresses outside the panel plane.

Possible causes may be: earthquake, lack of connections with orthogonal walls, presence of structures exerting pressure such as arches or vaults, or lack of verticality of the wall panel.

They occur according to the following possible mechanisms of collapse:

- **simple overturning**
- **vertical bending**
- **horizontal bending**

	MECHANISM OF COLLAPSE	POSSIBLE SOLUTION
<b>SIMPLE OVERTURNING</b>		<p>• Ref. data sheet 2.2 - 2.5</p> <p>Carbon fibre fabric Connectors</p> <ul style="list-style-type: none"> <li>• Wrappings with string course at the top and/or at the space between floors</li> <li>• Connections with the orthogonal walls</li> </ul>

	MECHANISM OF COLLAPSE	POSSIBLE SOLUTION
VERTICAL BENDING		<ul style="list-style-type: none"> <li>• Ref. data sheet 2.3 - 2.5</li> <li>• Fabric application over the strained area</li> <li>• Connections with the orthogonal walls</li> </ul>
HORIZONTAL BENDING		<ul style="list-style-type: none"> <li>• Ref. data sheet 2.4 - 2.5</li> <li>• Wrappings with string course at the top and/or at the space between floors</li> <li>• Connections with the orthogonal walls</li> <li>• Fabric application over the strained area</li> </ul>

In practice, mixed mechanism most commonly occur: they result from the combination of different collapse mechanisms described above.

### 3) SHEAR STRENGTHENING

Masonry wall panels can be reinforced with FRP materials in order to increase their lift or ductility in respect of stresses inside the panel plane which are usually caused by an earthquake, a lack of connections with orthogonal walls or the presence of structures exerting a pressure.

	MECHANISM OF COLLAPSE	POSSIBLE SOLUTION
SHEAR	<p>Stress parallel to the plane</p>	<ul style="list-style-type: none"> <li>• Ref. data sheet 2.5 - 2.6</li> <li>• System of braces for the containment of shear actions and system of vertical wrapping for the containment of combined bending and axial load actions</li> </ul>

### 4) ARCHES AND VAULTS • Ref. data sheet 2.7 - 2.8 - 2.9 - 2.10

The reinforcement of masonry vaults and arches is carried out when the structural elements lose their functionality because of the formation of hinges which trigger the collapse mechanisms. The causes are due to the poor tensile strength of the masonry which, when subjected to excessive loads and earthquakes, internally generates stresses that exhibit cracks and then the rotation of the springers. **The FRP reinforcement counteracts the formation of hinges by absorbing the tensile stresses that are generated within the structure.** The carbon fibre reinforcements are applied at the intrados, extrados or from both sides, depending on the static and/or application needs.

The reinforcements are then applied along those directions in which there are tensile stresses. The type and exact reinforcement scheme are determined by the modelling of the completed elements, but the experience, the full-scale experimentation and the theory of building science permit the determination of the indicative design patterns described in the data sheets below.

*As explained in the reinforced concrete section, what described in the following data sheets does not substitute the correct preliminary preparation of the support in order to obtain a substrate on which the reinforcement can be correctly applied, thus ensuring that the intervention is effective and long lasting. The interventions described are usually reinforcements that must be performed due to a change in how the structure is used or to the need to bring it into compliance with regulations.*

# MASONRY PILLAR

## 2.1

**THE PROBLEM** The compressive strength of the compressed pillar is below design requirements, or there is a need to increase the ultimate strain, for example, in the case of an increase in structural load or enlargement.

**THE SOLUTION** By wrapping the pillar with unidirectional tapes, the masonry compressive strength can be improved. The increase in compressive strength is achievable depending on section geometry, on source material and on the arrangement of the wraps applied around the entire perimeter, and it also leads to a ultimate compressive strain of the masonry, in other words it increases its ductility.

**PREPARATION** Restoration of the pillar is carried out through repointing joints interventions and/or reinforced injections. The sections on which the reinforcement will be applied should be realized with the mortar **FLUECO 40T** or **FLUECO 80T2**. The masonry section should be even and smooth. The pillar edges should be rounded to a radius of curvature of at least 20 mm.

**REINFORCEMENT APPLICATION**  
 On the restored masonry section, a coat of mortar **FLUECO 40T** or **FLUECO 80T2** should be applied to smooth the surface and provide a uniform substrate to the FRP reinforcement, whose thickness will depend on the surface irregularities. To prepare the substrate, a coat of the primer **ARMOPRIMER 100** should be applied by brush on the mortar, and within 2 hours **ARMOFIX MTX**, the adhesive for the bonding of carbon fibre fabrics, will be spread. Over this, the unidirectional carbon fibre fabric **ARMOSHIELD C-SHEET**, cut to the size needed, will be applied, with an overlapping of at least 20 cm orientated in the direction of fibres. The laid fabric should be properly rolled with a spiked metal roller to remove air bubbles that may have formed and to promote fibres impregnation. An additional coat of **ARMOFIX MTX** will be then laid on the fabric in order to complete impregnation, always by rolling. For any subsequent coats, lay an additional coat of **ARMOFIX MTX** over the fabric previously laid, then lay the second coat taking care to roll well to remove any air bubbles and perfectly impregnate the fibres. In order to allow the subsequent plaster application, sprinkle the last coat with quartz sand while the adhesive is still fresh.

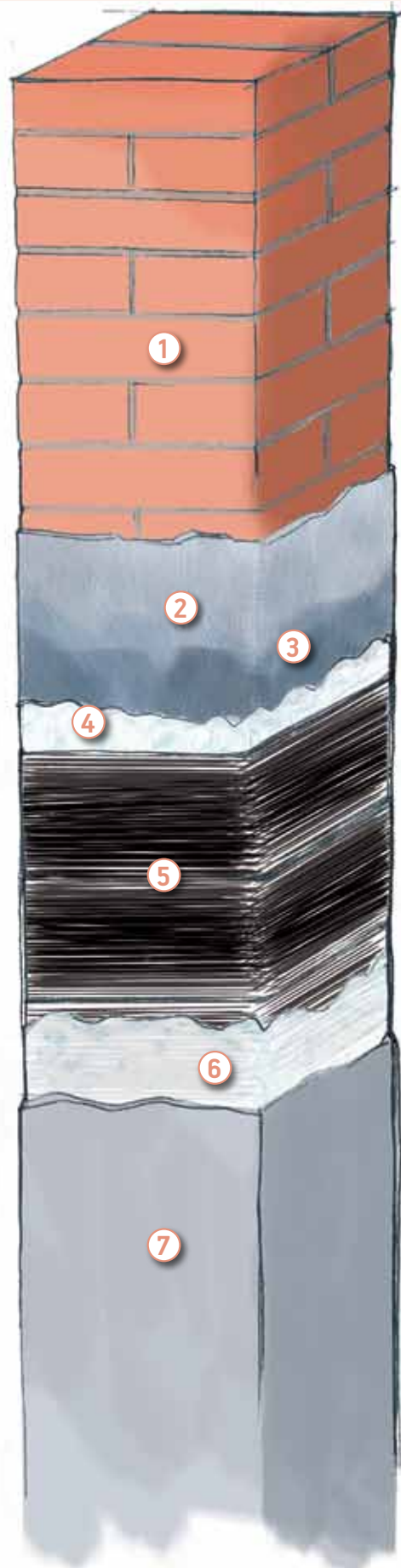

- ITEM SPECIFICATIONS**
- Substrate preparation 4.0.2 page 63
  - Item specifications Fabrics 4.1 page 64



# COMPRESSIVE STRENGTHENING THROUGH CONFINEMENT WITH CARBON FIBRE FABRICS



## LEGEND

- 1 Masonry pillar
- 2 Rendering using fibre-reinforced mortar FLUECO
- 3 ARMOPRIMER 100 primer
- 4 ARMOFIX MTX resin for bonding
- 5 ARMOSHIELD C-SHEET unidirectional carbon fibre
- 6 ARMOFIX MTX resin for impregnation
- 7 Finishing plaster



## DID YOU KNOW THAT...

*It is possible to improve the compressive behaviour of square or rectangular cross-section pillars also by using ARMOSHIELD BC bars placed horizontally, with and without wrapping.*



## FROM THE CONSTRUCTION SITE: APPLICATION IMAGES



*Compressed masonry pillar before intervention*



*Wrapping of the pillar with ARMOSHIELD C carbon fibre fabrics*



**Reference legislation for reinforcement sizing:** CNR DT 200 R1/2013 REV. 15/05/2014

Centred design compressive strength of the confined element      chap. 5.6.1

DOWNLOAD THE STANDARD: [http://www.cnr.it/sitocnr/IICNR/Attivita/NormazioneeCertificazione/DT200\\_R1.html](http://www.cnr.it/sitocnr/IICNR/Attivita/NormazioneeCertificazione/DT200_R1.html)

# PERIMETER WALL PANELS

## 2.2

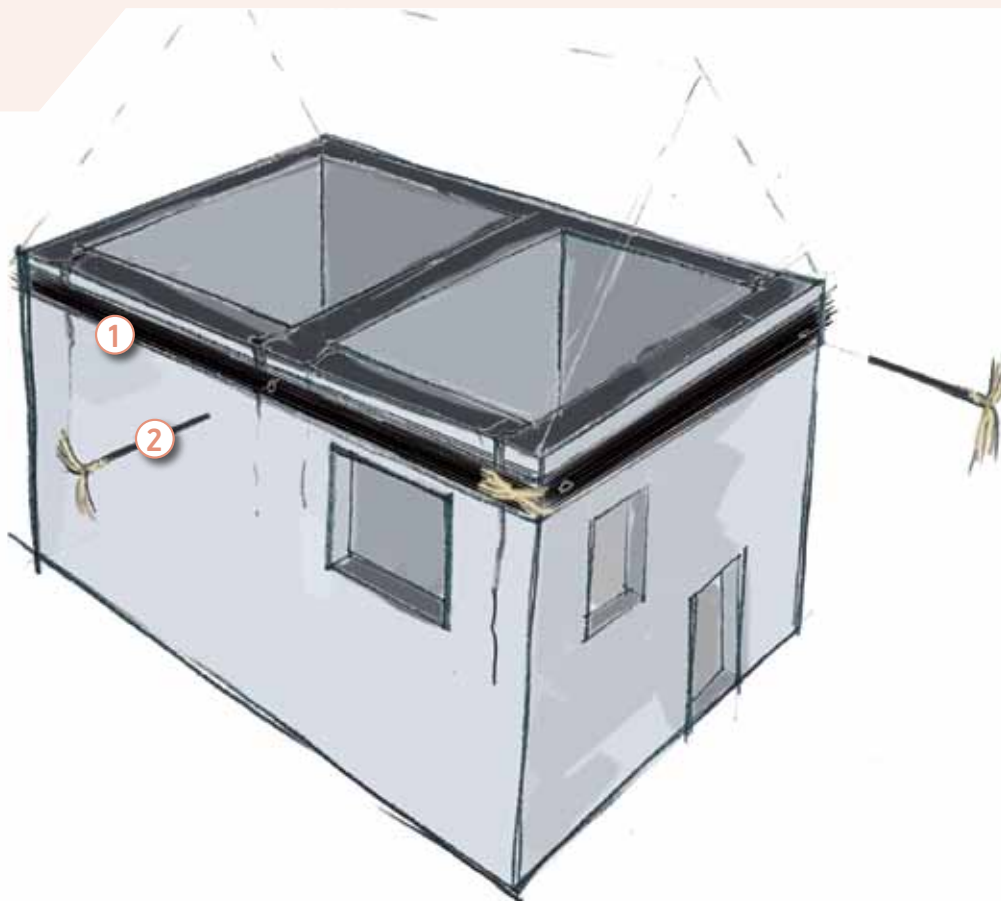

**THE PROBLEM** The overturning of the wall panel due to the collapse of the bottom hinge wall is expected.

**THE SOLUTION** Wrapping the top of the panel with appropriate turn up and anchoring to orthogonal walls. Alternative solution to maximise the benefits: full wrapping of the wall structure.

**PREPARATION** Restoration of the pillar is carried out by removing degraded elements even by repointing joints and/or reinforced injections. The sections on which the reinforcement will be applied should be realized with the mortar **FLUECO 40T** or **FLUECO 80T2**. Fibre reinforced mortar grooves should be realized for the housing of carbon fibre plates whose thickness will depend on the surface irregularities. The structure edges should be rounded to a radius of curvature of at least 20 mm.

**REINFORCEMENT APPLICATION**  
On the restored masonry section, a coat of mortar **FLUECO 40T** or **FLUECO 80T2** should be applied to smooth the surface and provide a uniform substrate to the FRP reinforcement, whose thickness will depend on the surface irregularities. To prepare the substrate, a coat of the primer Armoprimer 100 should be applied by brush on the mortar, and within 2 hours **ARMOFIX MTX**, the adhesive for the bonding of carbon fibre fabrics, will be spread. Over this, the unidirectional carbon fibre fabric **ARMOSHIELD C-SHEET**, cut to the size needed, will be applied; any cold joint should be made through simple overlap of at least 20 cm orientated in the direction of fibres. The laid fabric should be properly rolled with a spiked metal roller to remove air bubbles that may have formed and to promote fibres impregnation. An additional coat of **ARMOFIX MTX** will be then laid on the fabric in order to complete impregnation, always by rolling. For any subsequent coats, lay an additional coat of **ARMOFIX MTX** over the fabric previously laid, then lay the second coat taking care to roll well to remove any air bubbles and perfectly impregnate the fibres. In order to allow the subsequent plaster application, sprinkle the last coat with quartz sand while the adhesive is still fresh.

**ITEM SPECIFICATIONS**

- Substrate preparation	4.0.2	page 63
- Item specifications Fabrics	4.1	page 64

# REINFORCEMENT THROUGH WRAPPING WITH CARBON FIBRE FABRICS

## LEGEND

- 1 Wrapping with unidirectional fabric ARMOSHIELD C-SHEET laid on FLUECO mortar grooves
- 2 ARMOGRIP aramid connectors

**DID YOU KNOW THAT...**

*The FRP intervention may be optimized with an adequate prior restoration of masonry. Discover ARMOLIME products!*

## FROM THE CONSTRUCTION SITE: APPLICATION IMAGES



Wrapping with unidirectional fabric: detail of the rounded corner



Wrapping detail



Overview of the intervention: wrapping performed at the top and at the floor slab



**Reference legislation for reinforcement sizing:** CNR DT 200 R1/2013 REV. 15/05/2014

Verifying simple overturning	chap. 5.4.1.1.1
Verify at buckling in the plane of the panel	chap. 5.4.1.2.1
Verifying for cut in the floor panel	chap. 5.4.1.2.2
Delamination test (when needed)	chap. 5.3.2 - 5.3.3

DOWNLOAD THE STANDARD: [http://www.cnr.it/sitocnr/IICNR/Attivita/NormazioneeCertificazione/DT200\\_R1.html](http://www.cnr.it/sitocnr/IICNR/Attivita/NormazioneeCertificazione/DT200_R1.html)

# PERIMETER WALL PANELS

## 2.3

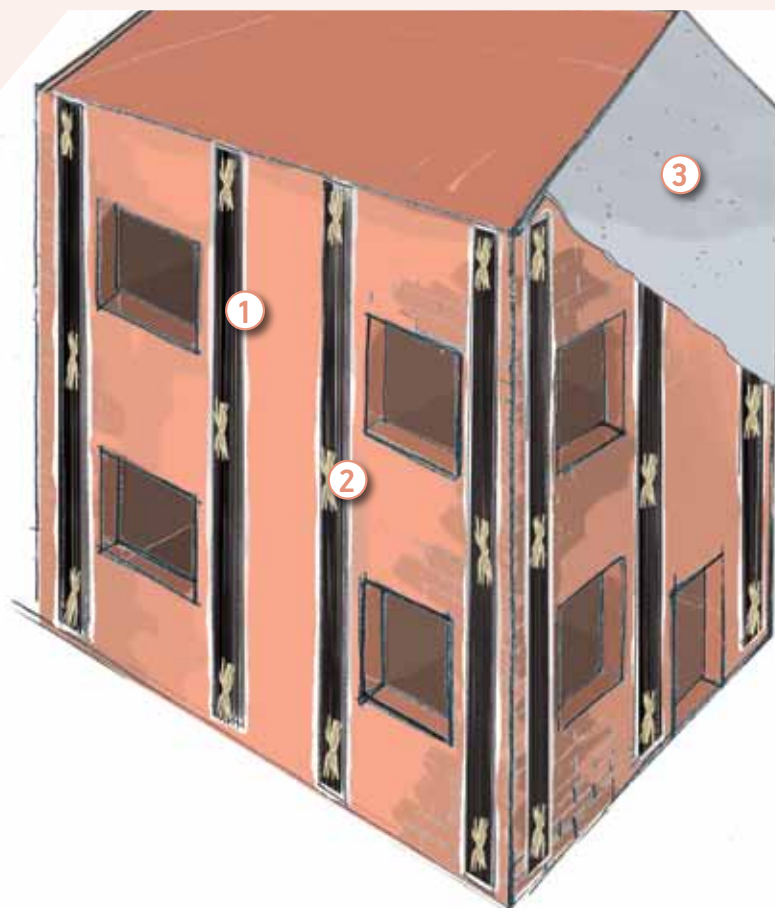

**THE PROBLEM** In a masonry panel well restrained at its bottom and top, subject to horizontal stresses, the collapse is expected as a result of the bending stresses that arise inside it. The collapse occurs as a result of the formation of three hinges: one at the bottom, one at the top and the third at a certain height of the panel.

**THE SOLUTION** By applying fabrics of FRP composite material on the walls of the panel, a "masonry reinforced with FRP" is created. Inside it, the compression stresses related to the bending are absorbed by the masonry, while tensile stresses are absorbed by the FRP reinforcement.

**PREPARATION** Fibre reinforced mortar grooves should be realized for the housing of carbon fibre wraps whose thickness will depend on the surface irregularities.

**REINFORCEMENT APPLICATION**  
 On the restored masonry section, a coat of mortar **FLUECO 40T** or **FLUECO 80T2** should be applied to smooth the surface and provide a uniform substrate to the FRP reinforcement, whose thickness will depend on the surface irregularities. To prepare the substrate, a coat of the primer **ARMOPRIMER 100** should be applied by brush on the mortar, and within 2 hours **ARMOFIX MTX**, the adhesive for the bonding of carbon fibre fabrics, will be spread. Over this, the unidirectional carbon fibre fabric **ARMOSHIELD C-SHEET**, cut to the size needed, will be applied; any cold joint should be made through simple overlap of at least 20 cm orientated in the direction of fibres. The laid fabric should be properly rolled with a spiked metal roller **ARMOROLLER** to remove air bubbles that may have formed and to promote fibres impregnation. An additional coat of **ARMOFIX MTX** will be then laid on the fabric in order to complete impregnation, always by rolling. For any subsequent coats, lay an additional coat of **ARMOFIX MTX** over the fabric previously laid, then lay the second coat taking care to roll well to remove any air bubbles and perfectly impregnate the fibres. In order to allow the subsequent plaster application, sprinkle the last coat with quartz sand while the adhesive is still fresh.

**ITEM SPECIFICATIONS**

- Substrate preparation	4.0.2	page 63
- Item specifications Fabrics	4.1	page 64

# VERTICAL FLEXURAL STRENGTHENING



## LEGEND

- 1 ARMOSHIELD C-SHEET carbon fibre fabrics laid on FLUECO mortar grooves
- 2 Grouted ARMOGRIP aramid connectors
- 3 Finishing plaster



## DID YOU KNOW THAT...

*Always verify the presence of in-plane rigid floor slabs.*



## FROM THE CONSTRUCTION SITE: APPLICATION IMAGES



Preparation of the grooves for the housing of fabrics (\*)



Laying of ARMOSHIELD C carbon fibre fabrics on the mortar housing grooves and insertion of ARMOGRIP connectors

(\*) In this case it was decided to change the vertical reinforcement (2.3) and the horizontal reinforcement (2.4)



### Reference legislation for reinforcement sizing: CNR DT 200 R1/2013 REV. 15/05/2014

Flexural testing of the vertical masonry strip	chap. 5.4.1.1.2
Delamination test (when needed)	chap. 5.3.2 - 5.3.3

DOWNLOAD THE STANDARD: [http://www.cnr.it/sitocnr/IICNR/Attivita/NormazioneeCertificazione/DT200\\_R1.html](http://www.cnr.it/sitocnr/IICNR/Attivita/NormazioneeCertificazione/DT200_R1.html)

# PERIMETER WALL PANELS

## 2.4

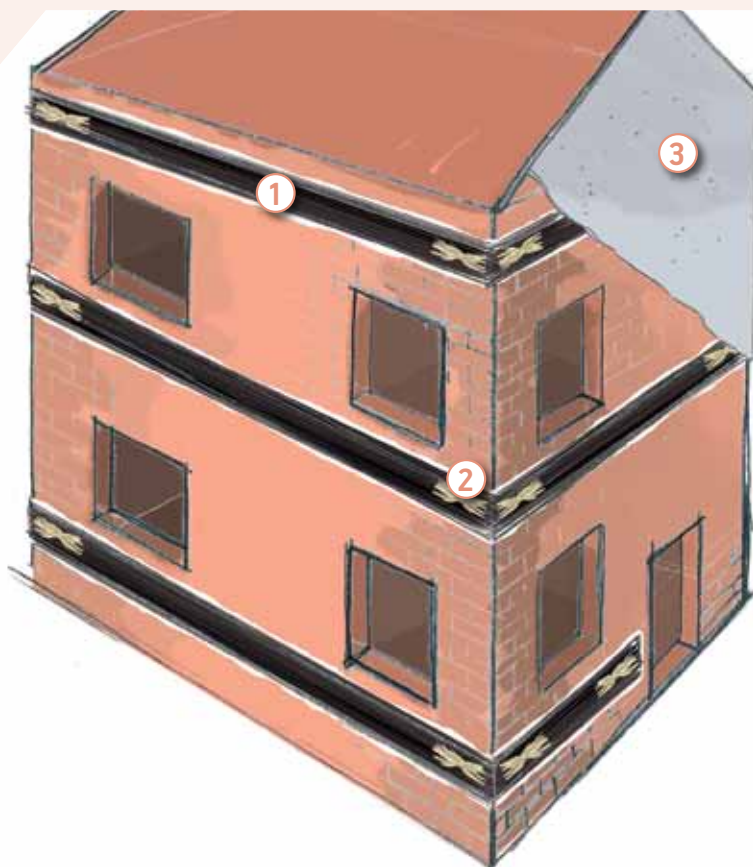

**? THE PROBLEM** In a masonry panel well restrained at its bottom, in the presence of side walls that are or are not able to exert buttress action in the presence of horizontal stresses, the horizontal top wall section behaves like a masonry beam, and could collapse due to an exceeding of the load capacity of the structural scheme, or due to the formation of the 3 hinges mechanism.

**👍 THE SOLUTION** The application of composite materials counteracts this mechanism, improving the flexural strength of the top section of the panel, which is thus transformed into a masonry beam reinforced with FRP.

**🕒 PREPARATION** Remove the existing plaster until reaching the masonry. Restoration of the pillar is carried out by removing degraded elements even by repointing joints and/or reinforced injections. The sections on which the reinforcement will be applied should be realized with ARMOTECH MONO, the mortar with low modulus of elasticity.

**✅ REINFORCEMENT APPLICATION**  
 On the restored masonry section, a coat of mortar **FLUECO 40T** or **FLUECO 80T2** should be applied to smooth the surface and provide a uniform substrate to the FRP reinforcement, whose thickness will depend on the surface irregularities. To prepare the substrate, a coat of the primer **ARMOPRIMER 100** should be applied by brush on the mortar, and within 2 hours **ARMOFIX MTX**, the adhesive for the bonding of carbon fibre fabrics, will be spread. Over this, the unidirectional carbon fibre fabric **ARMOSHIELD C-SHEET**, cut to the size needed, will be applied; any cold joint should be made through simple overlap of at least 20 cm orientated in the direction of fibres. The laid fabric should be properly rolled with a spiked metal roller to remove air bubbles that may have formed and to promote fibres impregnation. An additional coat of **ARMOFIX MTX** will be then laid on the fabric in order to complete impregnation, always by rolling. For any subsequent coats, lay an additional coat of **ARMOFIX MTX** over the fabric previously laid, then lay the second coat taking care to roll well to remove any air bubbles and perfectly impregnate the fibres. In order to allow the subsequent plaster application, sprinkle the last coat with quartz sand while the adhesive is still fresh.

**▶ ITEM SPECIFICATIONS**

- Substrate preparation 4.0.2 page 63
- Item specifications Fabrics 4.1 page 64

# HORIZONTAL FLEXURAL STRENGTHENING



## LEGEND

- 1 ARMOSHIELD C-SHEET carbon fibre fabrics laid on FLUECO mortar grooves
- 2 ARMOGRIP aramid connectors
- 3 Finishing plaster



## DID YOU KNOW THAT...

*The problem is more acute in the section below the roofline due to the wooden beams whose weight is not supported by the ground. Remember to take into account their action!*



## FROM THE CONSTRUCTION SITE: APPLICATION IMAGES



Preparation of the grooves for the housing of fabrics (\*)

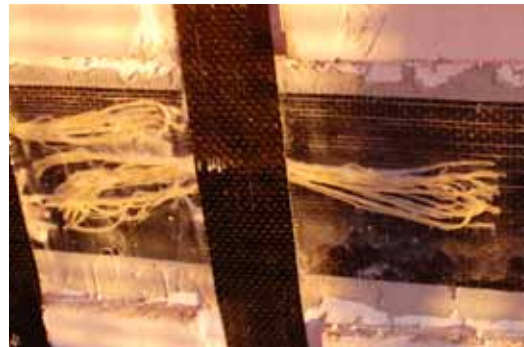

Wrapping with ARMOSHIELD C unidirectional carbon fibre fabrics (\*)



Wrapping with ARMOSHIELD C unidirectional carbon fibre fabrics



Detail of the final quartz sand sprinkle promoting the subsequent plaster application

(\*) In this case it was decided to change the vertical (2.3) and the horizontal (2.4) reinforcement.



### Reference legislation for reinforcement sizing: CNR DT 200 R1/2013 REV. 15/05/2014

Flexural testing of the vertical masonry strip	chap. 5.4.1.1.3
Delamination test (when needed)	chap. 5.3.2 - 5.3.3

DOWNLOAD THE STANDARD: [http://www.cnr.it/sitocnr/IICNR/Attivita/NormazioneeCertificazione/DT200\\_R1.html](http://www.cnr.it/sitocnr/IICNR/Attivita/NormazioneeCertificazione/DT200_R1.html)

# ORTHOGONAL MASONRY

## 2.5

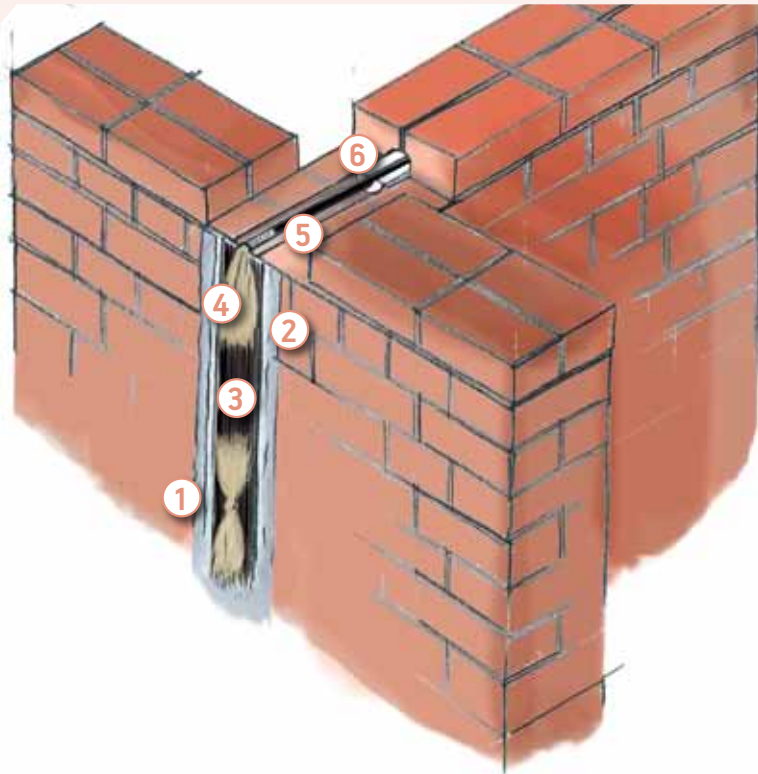

**THE PROBLEM** Orthogonal walls both resistant to horizontal stresses are insufficiently interlocked. This leads to a very bad seismic behaviour of the structure.

**THE SOLUTION** To apply carbon fibre bars together with vertical FRP wraps, thus providing a continuous anchoring between the connected walls.

**PREPARATION** Fibre reinforced mortar grooves should be realized for the housing of carbon fibre wraps whose thickness will depend on the surface irregularities, and holes with proper diameter and length should be drilled, such as to allow the insertion of the bars. The holes should be cleaned from dust.

**REINFORCEMENT APPLICATION**  
 On the restored masonry section, a coat of mortar **FLUECO 40T** or **FLUECO 80T2** should be applied to smooth the surface and provide a uniform substrate to the FRP reinforcement, whose thickness will depend on the surface irregularities. To prepare the substrate, a coat of the primer **ARMOPRIMER 100** should be applied by brush on the mortar, and within 2 hours **ARMOFIX MTX**, the adhesive for the bonding of carbon fibre fabrics, will be spread. Over this, the unidirectional carbon fibre fabric **ARMOSHIELD C-SHEET**, cut to the size needed, will be applied; any cold joint should be made through simple overlap of at least 20 cm orientated in the direction of fibres. The laid fabric should be properly rolled with a spiked metal roller to remove air bubbles that may have formed and to promote fibres impregnation. An additional coat of **ARMOFIX MTX** will be then laid on the fabric in order to complete impregnation, always by rolling. For any subsequent coats, lay an additional coat of **ARMOFIX MTX** over the fabric previously laid, then lay the second coat taking care to roll well to remove any air bubbles and perfectly impregnate the fibres. In order to allow the subsequent plaster application, sprinkle the last coat with quartz sand while the adhesive is still fresh. Before laying the last coat, **ARMOFIX** or **ARMOFIX MTX** adhesive should be cast or injected inside the hole, by filling it up to three-fourths of its depth; the bar will be inserted, the terminal part of the aramid connector which has not been impregnated and comes out of the hole (thread) will be spread and opened like a fan, then fixed to the surface surrounding the hole by resin impregnation. The adhesive should be applied first on the surface to be bonded and then on the fibres opened like a fan. A portion of carbon fibre fabric should be applied on the coat of resin while it is still fresh in order to protect the connector, by repeating the same carbon fibre wrapping cycle.

<b>ITEM SPECIFICATIONS</b>	- Substrate preparation	4.0.2	page 63
	- Item specifications Fabrics	4.1	page 64
	- Item specifications Connectors	4.7	page 80



# WALLS CONNECTION

## LEGEND

- 1 Fibre reinforced mortar section
- 2 Resin for bonding and impregnating
- 3 ARMOSHIELD C-SHEET carbon fibre fabric
- 4 ARMOGRIP aramid connector
- 5 ARMOSHIELD BC carbon bar
- 6 ARMOFIX MTX resin for bonding

## DID YOU KNOW THAT...

Often, the orthogonal walls connection together with the presence of in-plane rigid floor slabs greatly improves the seismic performance of a masonry building.



## FROM THE CONSTRUCTION SITE: APPLICATION IMAGES

### STEP 1



The fibres of carbon fabric must be carefully spread at the holes

### STEP 2



Insertion of the aramid connector ARMOGRIP BC inside the hole filled with ARMOFIX MTX resin

### STEP 3

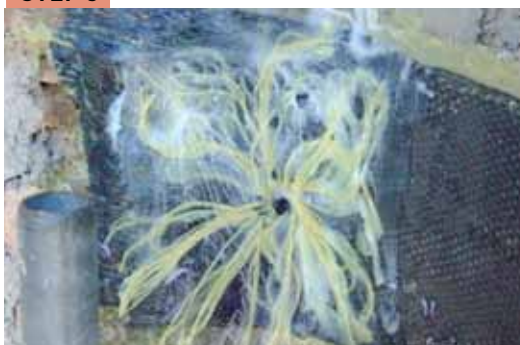

Fan-shaped opening of the thread and fixing with ARMOFIX MTX epoxy resin

### STEP 4



Portion of ARMOSHIELD C carbon fibre fabric applied on the thread to protect the connector



### Reference legislation for reinforcement sizing:

There are no specific regulations on FRP connector dimensioning, although CNR DT 200/2004 mentions it in chapter 5.1.3. However, it is possible to refer to the resistance characteristics declared by producers and to the indicative calculation of the anchor length according to ETAG 001 (taking to account that it has been calculated for steel bars anchored with chemical anchor).

DOWNLOAD THE STANDARD: [http://www.cnr.it/sitocnr/IIICNR/Attivita/NormazioneeCertificazione/DT200\\_R1.html](http://www.cnr.it/sitocnr/IIICNR/Attivita/NormazioneeCertificazione/DT200_R1.html)

# WALLS SUBJECTED TO SHEAR STRESS

## 2.6

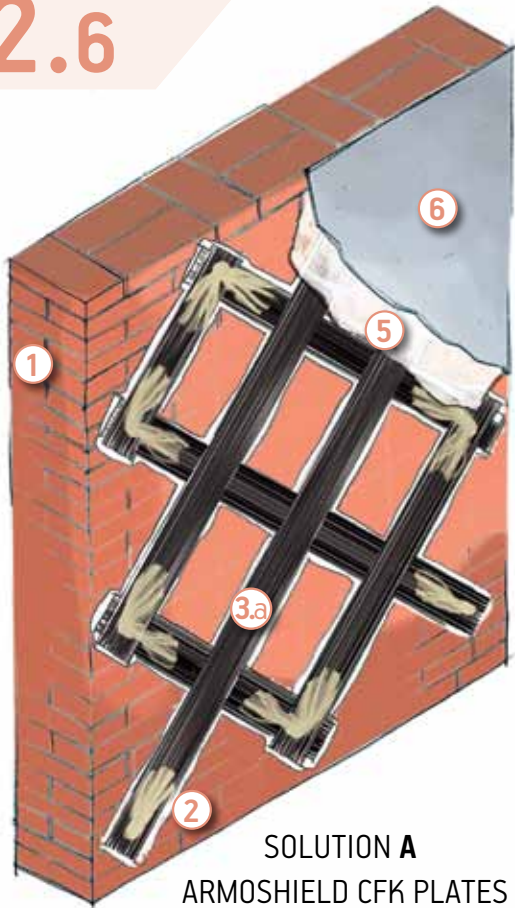

**SOLUTION A**  
ARMOSHIELD CFK PLATES

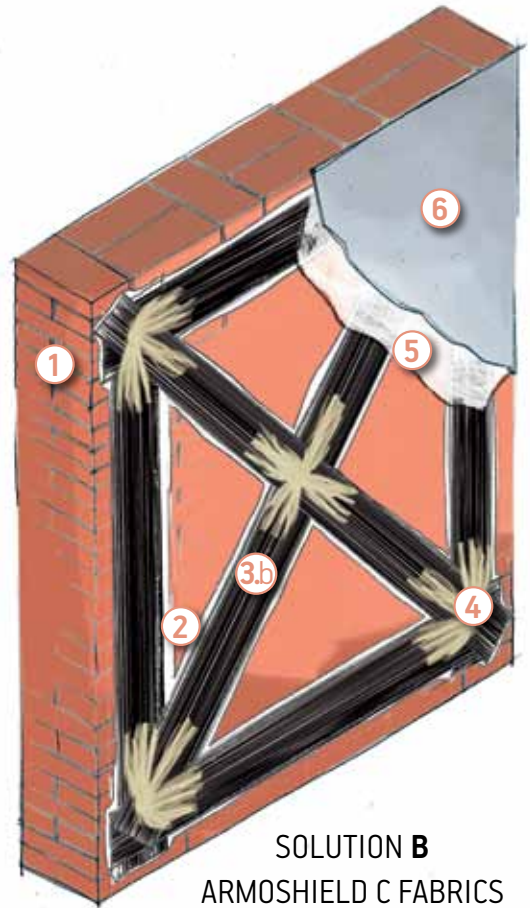

**SOLUTION B**  
ARMOSHIELD C FABRICS

**THE PROBLEM** To reinforce a masonry panel under shear stress.

**THE SOLUTION** To apply carbon fibre fabrics by wrapping both outer sides of the panel in order to create a system which activates a behaviour consistent with the truss model.

**PREPARATION** Fibre reinforced mortar grooves should be realized for the housing of carbon fibre wraps whose thickness will depend on the surface irregularities.

**REINFORCEMENT APPLICATION**

On the restored masonry section, a coat of mortar **FLUECO 40T** or **FLUECO 80T2** should be applied to smooth the surface and provide a uniform substrate to the FRP reinforcement, whose thickness will depend on the surface irregularities. To prepare the substrate, a coat of the primer **ARMOPRIMER 100** should be applied by brush on the mortar, and within 2 hours **ARMOFIX MTX**, the adhesive for the bonding of carbon fibre fabrics, will be spread. Over this, the unidirectional carbon fibre fabric **ARMOSHIELD C-SHEET**, cut to the size needed, will be applied; any cold joint should be made through simple overlap of at least 20 cm orientated in the direction of fibres. The laid fabric should be properly rolled with a spiked metal roller **ARMOROLLER** to remove air bubbles that may have formed and to promote fibres impregnation. An additional coat of **ARMOFIX MTX** will be then laid on the fabric in order to complete impregnation, always by rolling. For any subsequent coats, lay an additional coat of **ARMOFIX MTX** over the fabric previously laid, then lay the second coat taking care to roll well to remove any air bubbles and perfectly impregnate the fibres. In order to allow the subsequent plaster application, sprinkle the last coat with quartz sand while the adhesive is still fresh.

- ITEM SPECIFICATIONS**
- Substrate preparation 4.0.2 page 63
  - Item specifications Fabrics 4.1 page 64
  - Item specifications Connectors 4.7 page 80

# SHEAR STRENGTHENING



## LEGEND

- 1 Masonry wall
- 2 ARMOFIX MTX/MTL resin for bonding
- 3.a Reinforcement with ARMOSHIELD CFK plates on both sides
- 3.b ARMOSHIELD C-SHEET carbon fibre fabric on both sides
- 4 ARMOGRIP double aramid thread grouted with ARMOFIX MTX
- 5 Plaster



## DID YOU KNOW THAT...

Shear strengthening wrappings horizontally arranged increase the strength of the wall, while wrappings diagonally arranged also increase its stiffness, since they also act as braces. Always remember to check the combined bending and axial load strength of the wall.



## FROM THE CONSTRUCTION SITE: APPLICATION IMAGES



Fabric application on the mortar grooves



Wall reinforced on both sides with ARMOSHIELD C carbon fibre fabric placed according to the project model



Interconnections with ARMOGRIP double-thread aramid connector



Quartz sand sprinkle promoting the subsequent plaster application



### Reference legislation for reinforcement sizing: CNR DT 200 R1/2013 REV. 15/05/2014

Shear testing of the in-plane panel	chap. 5.4.1.2.2
Delamination test	chap. 5.3.2 - 5.3.3

DOWNLOAD THE STANDARD: [http://www.cnr.it/sitocnr/IIICNR/Attivita/NormazioneeCertificazione/DT200\\_R1.html](http://www.cnr.it/sitocnr/IIICNR/Attivita/NormazioneeCertificazione/DT200_R1.html)

# ARCHES

## 2.7

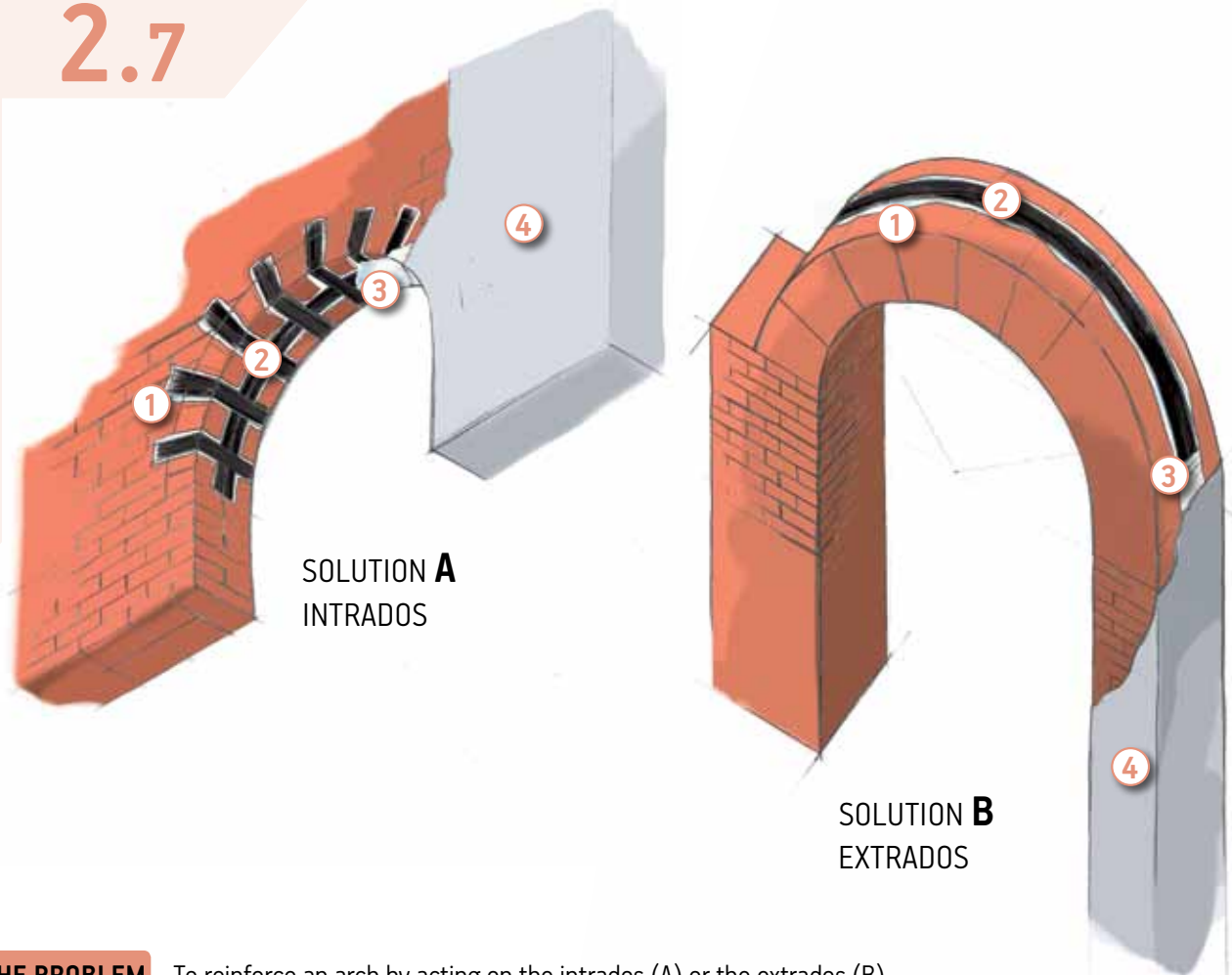

SOLUTION A  
INTRADOS

SOLUTION B  
EXTRADOS

**THE PROBLEM** To reinforce an arch by acting on the intrados (A) or the extrados (B).

**THE SOLUTION** Properly anchored wraps can be applied to the intrados in order to increase the permissible eccentricity of the resultant compressive stress in the arch thickness and thereby increase the loads that lead to the formation of plastic hinges that cause the collapse.

**PREPARATION** The degraded elements of the masonry must first be removed. Fibre reinforced mortar grooves should be realized for the housing of carbon fibre wraps whose thickness will depend on the surface irregularities.

**REINFORCEMENT APPLICATION**  
On the restored masonry section, a coat of mortar **FLUECO 40T** or **FLUECO 80T2** should be applied to smooth the surface and provide a uniform substrate to the FRP reinforcement, whose thickness will depend on the surface irregularities. To prepare the substrate, a coat of the primer **ARMOPRIMER 100** should be applied by brush on the mortar, and within 2 hours **ARMOFIX MTX**, the adhesive for the bonding of carbon fibre fabrics, will be spread. Over this, the unidirectional carbon fibre fabric **ARMOSHIELD C-SHEET**, cut to the size needed, will be applied; any cold joint should be made through simple overlap of at least 20 cm orientated in the direction of fibres. The laid fabric should be properly rolled with a spiked metal roller **ARMOROLLER** to remove air bubbles that may have formed and to promote fibres impregnation. An additional coat of **ARMOFIX MTX** will be then laid on the fabric in order to complete impregnation, always by rolling. For any subsequent coats, lay an additional coat of **ARMOFIX MTX** over the fabric previously laid, then lay the second coat taking care to roll well to remove any air bubbles and perfectly impregnate the fibres. In order to allow the subsequent plaster application, sprinkle the last coat with quartz sand while the adhesive is still fresh.

**ITEM SPECIFICATIONS**

- Substrate preparation 4.0.2 page 63
- Item specifications Fabrics 4.1 page 64



## LEGEND

- 1 ARMOFIX MTX adhesive for the bonding of fabrics
- 2 ARMOSHIELD C-SHEET unidirectional fabric
- 3 ARMOFIX MTX resin for impregnation
- 4 Finishing plaster



## DID YOU KNOW THAT...

*The intervention on the extrados is undoubtedly better, however the intervention on the intrados does not constitute a fall-back solution: indeed, it can result in significant improvements in the arch failure behaviour.*



## FROM THE CONSTRUCTION SITE: APPLICATION IMAGES



*The arch before the intervention: complete removal of plaster or existing coatings*



*Application of ARMOSHIELD C-SHEET fabrics to the intrados and wrapping secured with ARMOGRIP connectors.*



*Detail of the U-wraps and ARMOGRIP connectors*



**Reference legislation for reinforcement sizing:** CNR DT 200 R1/2013 REV. 15/05/2014

Arch scheme check	chap. 5.5.1.1
Arch-pier scheme check	chap. 5.5.1.2
Flexural test	chap. 5.4.1.1.2
Shear test	chap. 5.4.1.2.2
Delamination test	chap. 5.3.2 - 5.3.3

DOWNLOAD THE STANDARD: [http://www.cnr.it/sitocnr/IIICNR/Attivita/NormazioneeCertificazione/DT200\\_R1.html](http://www.cnr.it/sitocnr/IIICNR/Attivita/NormazioneeCertificazione/DT200_R1.html)

# BARREL VAULTS

## 2.8

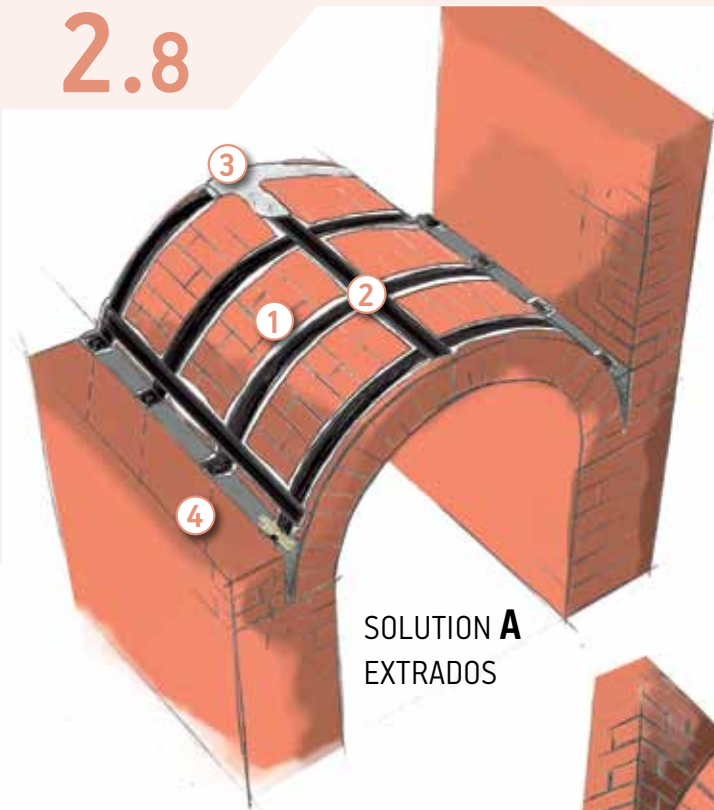

SOLUTION A  
EXTRADOS

**THE PROBLEM** To reinforce a barrel vault by acting on the intrados (A) or the extrados (B).

**THE SOLUTION** Wraps can be applied to the extrados or to the intrados (in this case the wraps must be mechanically anchored by connectors) in order to increase the permissible eccentricity of the resultant compressive stress in the vault thickness and thereby increase the loads that lead to the formation of the plastic hinge.

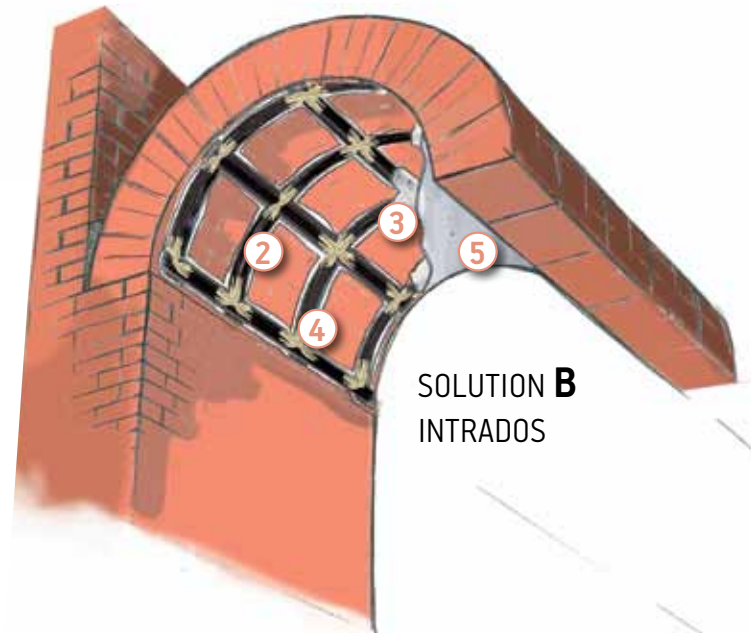

SOLUTION B  
INTRADOS

**PREPARATION** Restoration of the masonry is carried out through repointing joints interventions and/or reinforced injections. The sections on which the reinforcement will be applied should be realized with ARMOTECH MONO, the mortar with low modulus of elasticity. Fibre reinforced mortar grooves should be realized for the housing of carbon fibre wraps whose thickness will depend on the surface irregularities. In the case of intervention on the extrados, check that the vault is adequately propped up before removing its infill.

**REINFORCEMENT APPLICATION** On the restored masonry section, a coat of mortar **FLUECO 40T** or **FLUECO 80T2** should be applied to smooth the surface and provide a uniform substrate to the FRP reinforcement, whose thickness will depend on the surface irregularities. To prepare the substrate, a coat of the primer **ARMOPRIMER 100** should be applied by brush on the mortar, and within 2 hours **ARMOFIX MTX**, the adhesive for the bonding of carbon fibre fabrics, will be spread. Over this, the unidirectional carbon fibre fabric **ARMOSHIELD C-SHEET**, cut to the size needed, will be applied; any cold joint should be made through simple overlap of at least 20 cm orientated in the direction of fibres. The laid fabric should be properly rolled with a spiked metal roller **ARMOROLLER** to remove air bubbles that may have formed and to promote fibres impregnation. An additional coat of **ARMOFIX MTX** will be then laid on the fabric in order to complete impregnation, always by rolling. For any subsequent coats, lay an additional coat of **ARMOFIX MTX** over the fabric previously laid, then lay the second coat taking care to roll well to remove any air bubbles and perfectly impregnate the fibres. In order to allow the subsequent plaster application, sprinkle the last coat with quartz sand while the adhesive is still fresh.

- ITEM SPECIFICATIONS**
- Substrate preparation 4.0.2 page 63
  - Item specifications Fabrics 4.1 page 64

# INTRADOS/EXTRADOS STRENGTHENING



## LEGEND

- 1 ARMOFIX MTX resin for bonding
- 2 ARMOSHIELD C-SHEET unidirectional fabrics
- 3 ARMOFIX MTX resin for impregnation
- 4 Carbon aramid connectors + ARMOGRIP BC bars
- 5 Finishing plaster



## DID YOU KNOW THAT...

*Remember to anchor the vaults to the masonry only where this connection does not prevent the normal strain of the vault, usually occurring at the supporting points of the structure.*



## FROM THE CONSTRUCTION SITE: APPLICATION IMAGES



*The barrel vault before the intervention: removal of the surface coating*



*Detail of the roof connection to the perimeter wall*



*Application on the extrados*



*Application on the intrados*



### Reference legislation for reinforcement sizing: CNR DT 200 R1/2013 REV. 15/05/2014

Single curvature vaults - barrel vaults	chap. 5.5.2
Flexural test	chap. 5.4.1.1.2
Shear test	chap. 5.4.1.2.2
Delamination test	chap. 5.3.2 - 5.3.3

DOWNLOAD THE STANDARD: [http://www.cnr.it/sitocnr/IICNR/Attivita/NormazioneeCertificazione/DT200\\_R1.html](http://www.cnr.it/sitocnr/IICNR/Attivita/NormazioneeCertificazione/DT200_R1.html)

# GROIN VAULTS

## 2.9



SOLUTION A  
EXTRADOS

**?** **THE PROBLEM** To reinforce a groin vault by acting on the extrados (A) or the intrados (B).

**!** **THE SOLUTION** Wraps can be applied to the extrados or to the intrados (in this case the wraps must be mechanically anchored by connectors) in order to increase the permissible eccentricity of the resultant compressive stress in the vault thickness and thereby increase the loads that lead to the formation of the plastic hinge.

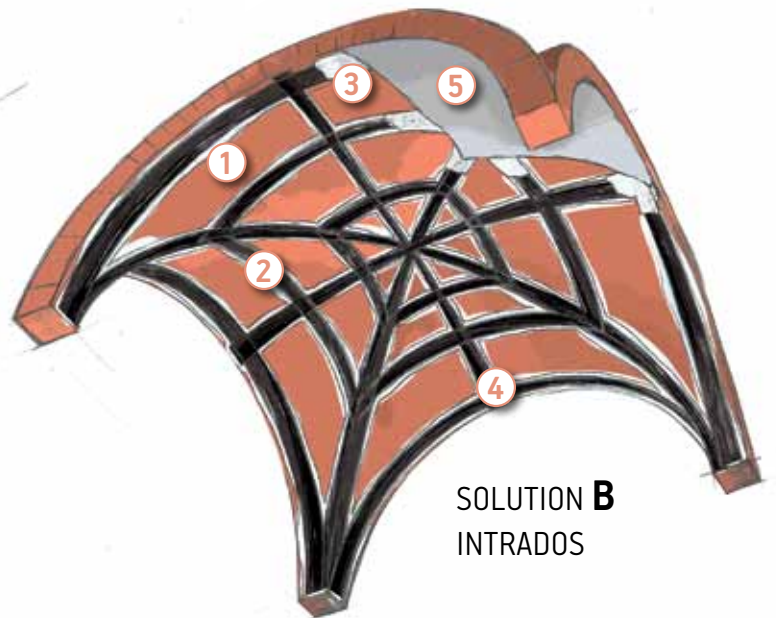

SOLUTION B  
INTRADOS

**○ PREPARATION** Restoration of the masonry is carried out through repointing joints interventions and/or reinforced injections. The sections on which the reinforcement will be applied should be realized with **ARMOTECH MONO**, the mortar with low modulus of elasticity. Fibre reinforced mortar grooves should be realized for the housing of carbon fibre wraps whose thickness will depend on the surface irregularities. In the case of intervention on the extrados, check that the vault is adequately propped up before removing its infill.

**✓ REINFORCEMENT APPLICATION**  
On the restored masonry section, a coat of mortar **FLUECO 40T** or **FLUECO 80T2** should be applied to smooth the surface and provide a uniform substrate to the FRP reinforcement, whose thickness will depend on the surface irregularities. To prepare the substrate, a coat of the primer **ARMOPRIMER 100** should be applied by brush on the mortar, and within 2 hours **ARMOFIX MTX**, the adhesive for the bonding of carbon fibre fabrics, will be spread. Over this, the unidirectional carbon fibre fabric **ARMOSHIELD C-SHEET**, cut to the size needed, will be applied; any cold joint should be made through simple overlap of at least 20 cm orientated in the direction of fibres. The laid fabric should be properly rolled with a spiked metal roller **ARMOROLLER** to remove air bubbles that may have formed and to promote fibres impregnation. An additional coat of **ARMOFIX MTX** will be then laid on the fabric in order to complete impregnation, always by rolling. For any subsequent coats, lay an additional coat of **ARMOFIX MTX** over the fabric previously laid, then lay the second coat taking care to roll well to remove any air bubbles and perfectly impregnate the fibres. In order to allow the subsequent plaster application, sprinkle the last coat with quartz sand while the adhesive is still fresh.

- ▶ ITEM SPECIFICATIONS**
- Substrate preparation 4.0.2 page 63
  - Item specifications Fabrics 4.1 page 64



# INTRADOS/EXTRADOS STRENGTHENING



## LEGEND

- 1 ARMOFIX MTX resin for bonding
- 2 ARMOSHIELD C-SHEET unidirectional fabrics
- 3 ARMOFIX MTX resin for impregnation
- 4 Carbon aramid connectors + ARMOGRIP BC bars
- 5 Finishing plaster



## DID YOU KNOW THAT...

*The mortar housing grooves ensure the reversibility of the intervention: this is why the FRP have become part of the guidelines for interventions on cultural and historical local heritage.*



## FROM THE CONSTRUCTION SITE: APPLICATION IMAGES



*The groin vault before the intervention after cleaning*



*Particular of the points of connection between the vault and the perimeter wall*



*Application of the resin for bonding*



*Overview of the reinforcement applied to the extrados and nearing completion*



### Reference legislation for reinforcement sizing: CNR DT 200 R1/2013 REV. 15/05/2014

Single curvature vaults	chap. 5.5.2
Flexural test	chap. 5.4.1.1.2
Shear test	chap. 5.4.1.2.2
Delamination test	chap. 5.3.2 - 5.3.3

DOWNLOAD THE STANDARD: [http://www.cnr.it/sitocnr/IICNR/Attivita/NormazioneeCertificazione/DT200\\_R1.html](http://www.cnr.it/sitocnr/IICNR/Attivita/NormazioneeCertificazione/DT200_R1.html)

# DOMES

## 2.10

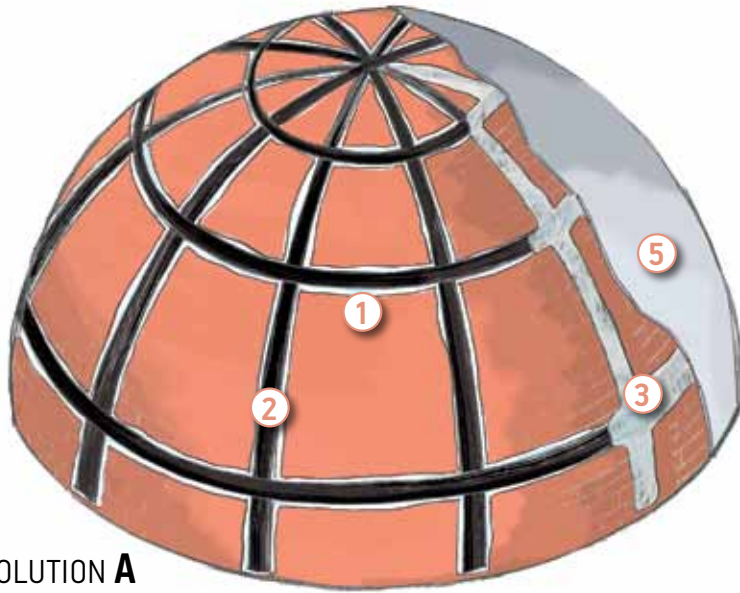

**SOLUTION A**  
EXTRADOS

**? THE PROBLEM** To reinforce a dome or a sail vault by acting on the extrados (A) or the intrados (B).

**👍 THE SOLUTION** Wraps can be applied to the extrados or to the intrados (in this case the wraps must be mechanically anchored by connectors) in order to increase the permissible eccentricity of the resultant compressive stress in the vault thickness and thereby increase the loads that lead to the formation of the plastic hinge.

**○ PREPARATION** Restoration of the masonry is carried out through repointing joints interventions and/or reinforced injections. The sections on which the reinforcement will be applied should be realized with **ARMOTECH MONO**, the mortar with low modulus of elasticity. Fibre reinforced mortar grooves should be realized for the housing of carbon fibre wraps whose thickness will depend on the surface irregularities. In the case of intervention on the extrados, check that the vault is adequately propped up before removing its infill.

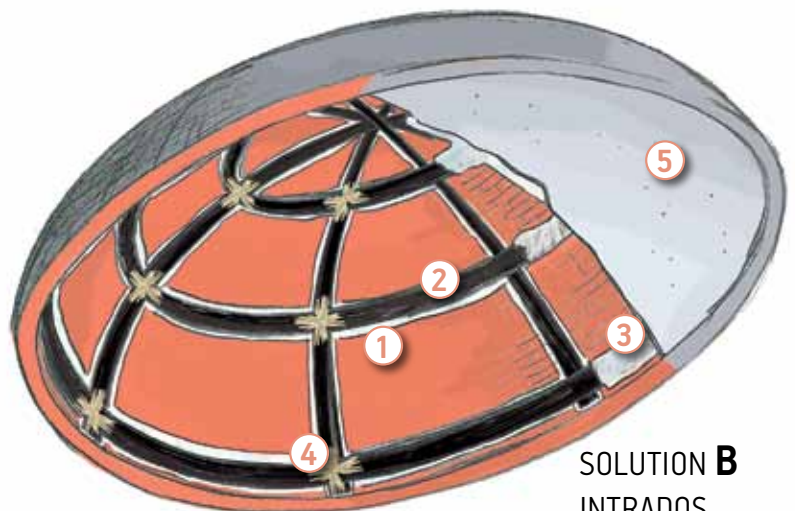

**SOLUTION B**  
INTRADOS

**✓ REINFORCEMENT APPLICATION** On the restored masonry section, a coat of mortar **FLUECO 40T** or **FLUECO 80T2** should be applied to smooth the surface and provide a uniform substrate to the FRP reinforcement, whose thickness will depend on the surface irregularities. To prepare the substrate, a coat of the primer **ARMOPRIMER 100** should be applied by brush on the mortar, and within 2 hours **ARMOFIX MTX**, the adhesive for the bonding of carbon fibre fabrics, will be spread. Over this, the unidirectional carbon fibre fabric **ARMOSHIELD C-SHEET**, cut to the size needed, will be applied; any cold joint should be made through simple overlap of at least 20 cm orientated in the direction of fibres. The laid fabric should be properly rolled with a spiked metal roller **ARMOROLLER** to remove air bubbles that may have formed and to promote fibres impregnation. An additional coat of **ARMOFIX MTX** will be then laid on the fabric in order to complete impregnation, always by rolling. For any subsequent coats, lay an additional coat of **ARMOFIX MTX** over the fabric previously laid, then lay the second coat taking care to roll well to remove any air bubbles and perfectly impregnate the fibres. In order to allow the subsequent plaster application, sprinkle the last coat with quartz sand while the adhesive is still fresh.

- ▶ ITEM SPECIFICATIONS**
- Substrate preparation 4.0.2 page 63
  - Item specifications Fabrics 4.1 page 64



## LEGEND

- 1 ARMOFIX MTX resin for bonding
- 2 ARMOSHIELD C-SHEET unidirectional fabrics
- 3 ARMOFIX MTX resin for impregnation
- 4 ARMOGRIP BC carbon aramid connectors
- 5 Finishing plaster



## DID YOU KNOW THAT...

*It is possible repointing masonry joints and restore any existing cracks by using the natural lime-based mortar ARMOLIME TA.*



## FROM THE CONSTRUCTION SITE: APPLICATION IMAGES



Application of ARMOSHIELD fabrics on the mortar grooves



### Reference legislation for reinforcement sizing: CNR DT 200 R1/2013 REV. 15/05/2014

Double-curvature vaults - domes	chap. 5.5.3
Double-curvature vaults on a square plan	chap. 5.5.4
Flexural test	chap. 5.4.1.1.2
Shear test	chap. 5.4.1.2.2
Delamination test	chap. 5.3.2 - 5.3.3

DOWNLOAD THE STANDARD: [http://www.cnr.it/sitocnr/IICNR/Attivita/NormazioneeCertificazione/DT200\\_R1.html](http://www.cnr.it/sitocnr/IICNR/Attivita/NormazioneeCertificazione/DT200_R1.html)

# ANCHORING DEVICES

## 2.11



**? THE PROBLEM** The anchoring length of the fibres is greater than the space available; there are concavities that would cause the reinforcement debonding if it is subject to tensile stresses.

**👍 THE SOLUTION** The FRP reinforcement (fabric or plate) can be anchored by fibrous material grouting (aramid or carbon) in order to ensure stress transfer continuity and material homogeneity even beyond the terminal section of the reinforcement, or to place an intermediate mechanical anchor.

**🕒 PREPARATION** A hole with proper diameter and length should be drilled, such as to allow the application of the connector or the threaded bar. The hole should be properly cleaned from drilling residues.

**✅ REINFORCEMENT APPLICATION** Inject **ARMOFIX MT** or **MTX** inside the hole taking care to fill approximately half of it, insert the connector **ARMOGRIP** inside the hole and proceed with the impregnation and filling of the connector cavity for its entire length with **ARMOFIX MT** or **MTX**. The connector portion which has not been impregnated and comes out of the hole (thread) should be opened like a fan and fixed to the surface surrounding the hole by resin impregnation. The adhesive should be applied first on the surface to be bonded and then on the fibres opened like a fan. A portion of carbon fibre fabric should be applied on the coat of resin while it is still fresh in order to protect the connector, by repeating the same carbon fibre fabric wrapping cycle.

**▶ ITEM SPECIFICATIONS**

- Substrate preparation	4.0.2	page 63
- Item specifications Fabrics	4.1	page 64



**LEGEND**

- 1 FLUECO mortar housing section and ARMOFIX MTX resin for bonding
- 2 ARMOSHIELD C-SHEET unidirectional fabric
- 3 ARMOGRIP BC carbon aramid connectors



**DID YOU KNOW THAT...**

*Anchoring is useful when stresses are perpendicular to the bonding surface and tend to debond the fibre, for instance in cases of application on concave surfaces (intrados of curved elements).*



**FROM THE CONSTRUCTION SITE: APPLICATION IMAGES**

**STEP 1**

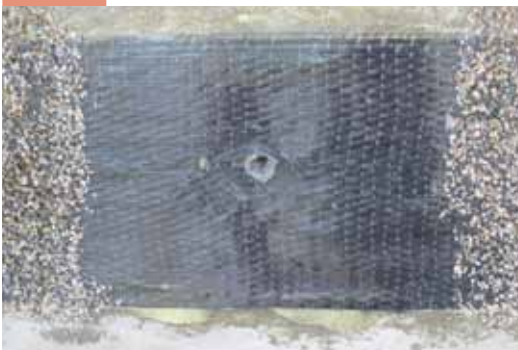

*The fibres must be carefully spread at the holes*

**STEP 2**



*Insertion of ARMOGRIP BC aramid connector*

**STEP 3**

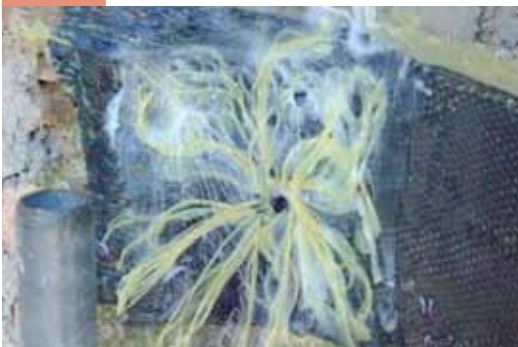

*Fan-shaped opening of the thread and fixing with ARMOFIX MTX*

**STEP 4**



*Portion of carbon fibre fabric applied on the thread to protect the connector*



**Reference legislation for reinforcement sizing:**

There are no specific regulations on FRP connector dimensioning, although CNR DT 200/2004 mentions it in chapter 5.1.3. However, it is possible to refer to the resistance characteristics declared by producers and to the indicative calculation of the anchor length according to ETAG 001 (taking to account that it has been calculated for steel bars anchored with chemical anchor).

DOWNLOAD THE STANDARD: [http://www.cnr.it/sitocnr/IICNR/Attivita/NormazioneeCertificazione/DT200\\_R1.html](http://www.cnr.it/sitocnr/IICNR/Attivita/NormazioneeCertificazione/DT200_R1.html)

# STRUCTURES

This chapter describes the main and most common issues concerning the structural reinforcement of load-bearing wooden elements. We will examine FRP reinforcements applied to improve the resistance of structural elements mainly subject to bending. Wood is a natural element and is not uniform because the type and concentration of defects that characterise each single piece can vary a lot. That is why, to design and place structural reinforcements on wooden elements, it is fundamental to carry out accurate analyses of the wooden components with suitable surveys and tests to establish the state of the element and determine the correct intervention according to the specific problem detected. The more meticulous the evaluation, the more accurate the results of the analyses.

The purpose of the FRP reinforcement of wooden structures is to confer greater resistance and stiffness to the structural elements, above all within the existing structures, inasmuch as this system permits their conservation with minimal invasiveness. The use of FRP is especially recommended in decorated structures and in the preservation of the Cultural Heritage. The fields of application are manifold: the main one is the reinforcement of wooden elements subjected to bending.

### Types of flexural reinforcements • Ref. data sheet 3.1 - 3.2

Following are some types of reinforcement on the strained area of wooden elements with the most commonly used plates or fabrics:



Since the cut that is made is extremely small (a few mm), the final intervention appears to be almost invisible and therefore suitable in the case of historical decorated floor slabs.

Finally, special attention must be paid to the environmental conditions surrounding the structure, as wood is susceptible to moisture - it dilates or contracts the material causing detachments or stress due to the fact that the reinforcement impedes dilation/contraction. In this case too, the bonding surface must be suitably prepared to guarantee the correct stress transmission and must be clean with no traces of dust, varnish and other oily or greasy elements.

WOOD



# WOODEN BEAM

## 3.1

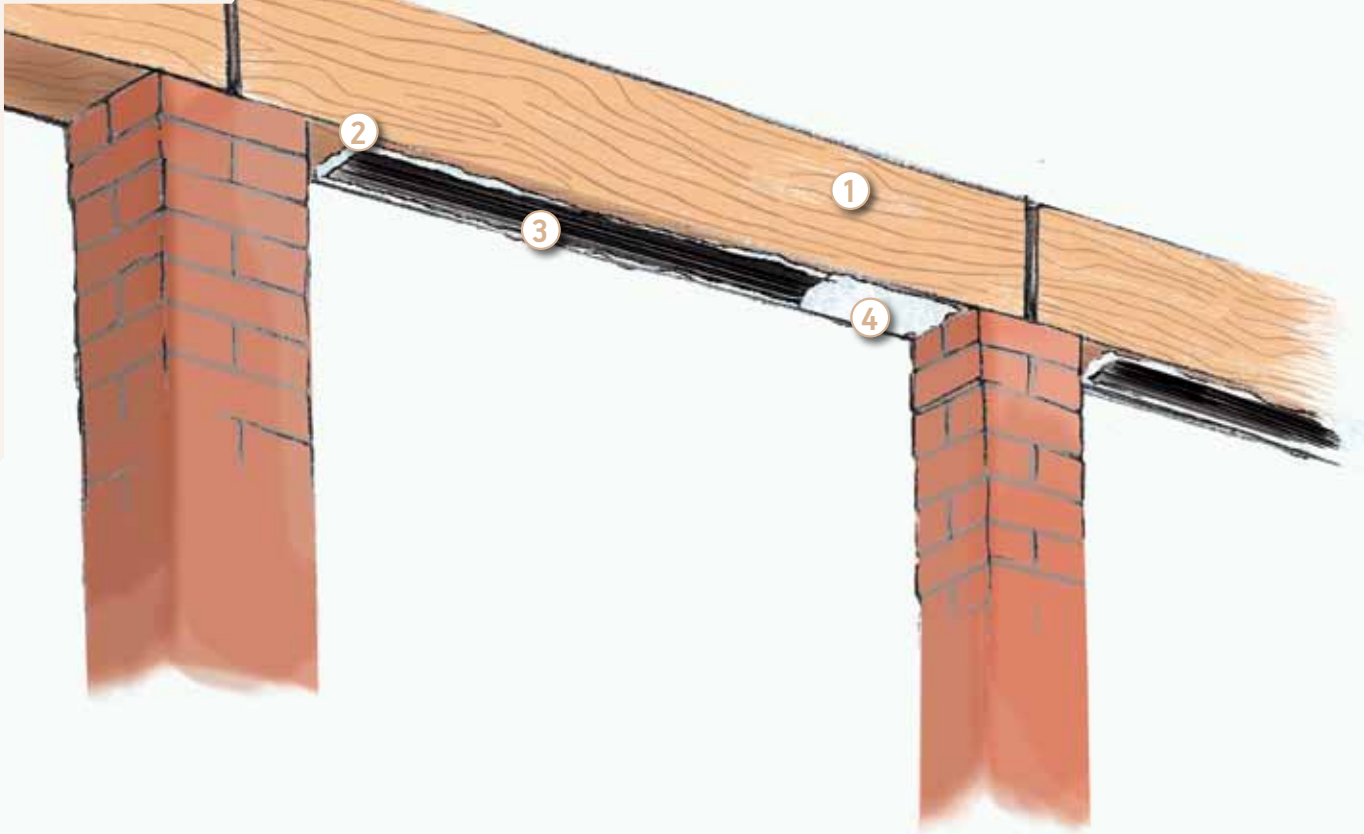

**THE PROBLEM** The wooden beam has flexural deficiencies caused by a change in load conditions or by a degradation of the initial performances of the materials.

**THE SOLUTION** The strained area of the beam may be reinforced by the use of unidirectional carbon fibre fabrics, with fibres placed parallel to the axis of the beam, and directly bonded to the intrados of the beam itself.

**PREPARATION** Remove coatings and any treatment previously performed on the intrados of the beam, verify its flatness and evenness, fill any longitudinal cracks with an elastic adhesive that does not prevent the seasonal movement of the wood.

### REINFORCEMENT APPLICATION

To prepare the substrate, a coat of the primer **ARMOPRIMER 100** should be applied by brush on the wooden beam which has been previously cleaned, and within 2 hours **ARMOFIX MTX**, the adhesive for the bonding of carbon fibre fabrics, will be spread. Over this, the unidirectional carbon fibre tape **ARMOSHIELD C-SHEET** will be applied. The tape must be properly rolled with **ARMOROLLER** spiked metal roller to remove air bubbles that may have formed and to promote adhesive penetration into the fibres for their first impregnation. The final impregnation will be performed by using the same adhesive **ARMOFIX MTX** applied on the fibre, which will be then rolled again with the metal roller. Check that all the fibres of the fabric are perfectly impregnated. For any subsequent coat, lay the fabric over the adhesive while it is still fresh and proceed with the impregnation as described above. In order to allow the plaster to grip, sprinkle the last coat with quartz sand while the impregnating adhesive is still fresh.

**ITEM SPECIFICATIONS** - Item specifications Wood

4.4 page 74



# FLEXURAL STRENGTHENING WITH CARBON FIBRE FABRIC

## LEGEND

- 1 Wooden beam
- 2 ARMOFIX MTX resin for bonding and impregnation
- 3 ARMOSHIELD C-SHEET carbon fibre fabric
- 4 Resin and sprinkle of quartz sand

## DID YOU KNOW THAT...

*The intervention is quick, simple, and ideal for attics. It is important to protect it from UV rays.*



## FROM THE CONSTRUCTION SITE: APPLICATION IMAGES



*Application of ARMOSHIELD C SHEET carbon fibre fabrics to the intrados of the beam*

## Reference legislation for reinforcement sizing: CNR DT 200 R1/2013 REV. 15/05/2014

Flexural test at ULS	chap. 6.4
Service Limit State (SLS) Check	chap. 4.2.3.2 (CNR DT 200 R1/2013 rev. 15/05/2014)

DOWNLOAD THE STANDARD: [http://www.cnr.it/sitocnr/IICNR/Attivita/NormazioneeCertificazione/DT200\\_R1.html](http://www.cnr.it/sitocnr/IICNR/Attivita/NormazioneeCertificazione/DT200_R1.html)

# WOODEN BEAM

## 3.2

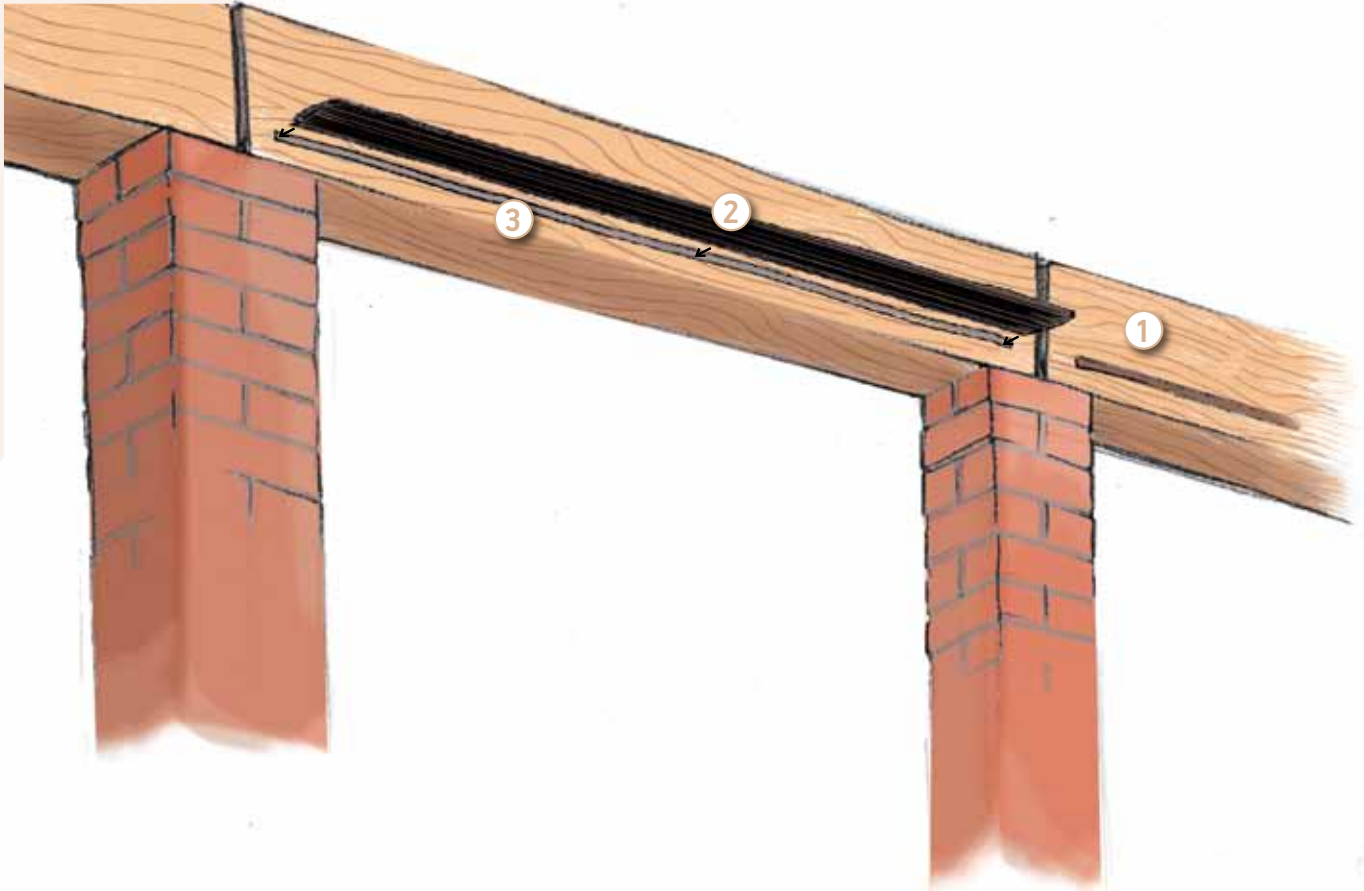

**? THE PROBLEM** The wooden beam has flexural deficiencies caused by a change in load conditions or by a degradation of the initial performances of the materials.

**👍 THE SOLUTION** The strained area of the beam may be reinforced by the use of pultruded carbon fibre plates, with fibres placed parallel to the axis of the beam, and inserted in dedicated slots placed on the side walls or on the intrados. This intervention is particularly useful when it should not be visible or when beams are decorated.

**🕒 PREPARATION** Millings with proper depth and length should be performed, such as to allow the insertion of the plates and the adhesive on the vertical wall or on the beam intrados; thoroughly clean them. Apply adhesive tape on the edges of the slot to protect the wood.

**✅ REINFORCEMENT APPLICATION**  
Inject the primer **ARMOPRIMER 100** in the slot and within 2 hours inject the adhesive **ARMOFIX MTX** so as to fill about three-quarters of the slot depth. Insert the plate pushing it to the bottom of the slot and remove excess adhesive. Fill the slot by grouting with the same bonding resin mixed with the sawdust produced during the milling, or seal with a slat cut to the size needed (in this case, the milling must be performed a few millimetres deeper).

**▶ ITEM SPECIFICATIONS** - Item specifications Wood 4.5 page 76

# FLEXURAL STRENGTHENING WITH CARBON FIBRE PLATES

## LEGEND

- ① Wooden beam
- ② ARMOSHIELD C carbon fibre plate
- ③ Milling filled with bonding resin

## DID YOU KNOW THAT...

*If the building site conditions allow, in order to take advantage of the carbon you can camber the wooden beams before inserting the plate, so as to make the reinforcement work even for permanent loads.*



## FROM THE CONSTRUCTION SITE: APPLICATION IMAGES

### STEP 1



Realization of the slot for the plate housing

### STEP 2



Injection of ARMOFIX MTX adhesive

### STEP 3



Insertion of ARMOSHIELD CFK plate

**Reference legislation for reinforcement sizing:** CNR DT 200 R1/2013 REV. 15/05/2014

Flexural test at ULS

chap. 6.4

Service Limit State (SLS) Check

chap. 4.2.3.2 (CNR DT 200 R1/2013 rev. 15/05/2014)

DOWNLOAD THE STANDARD: [http://www.cnr.it/sitocnr/IICNR/Attivita/NormazioneeCertificazione/DT200\\_R1.html](http://www.cnr.it/sitocnr/IICNR/Attivita/NormazioneeCertificazione/DT200_R1.html)

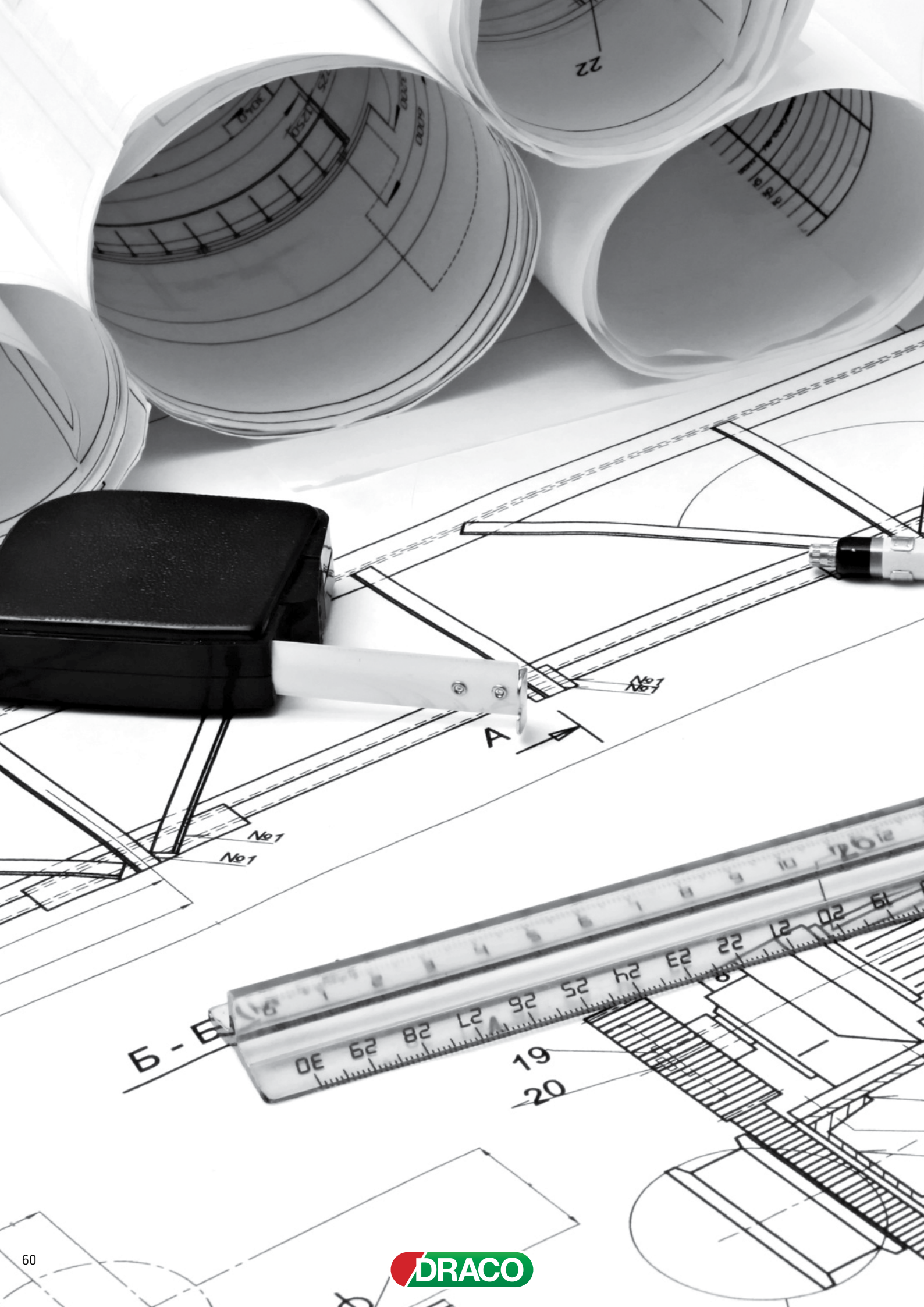

# ITEM SPECIFICATIONS

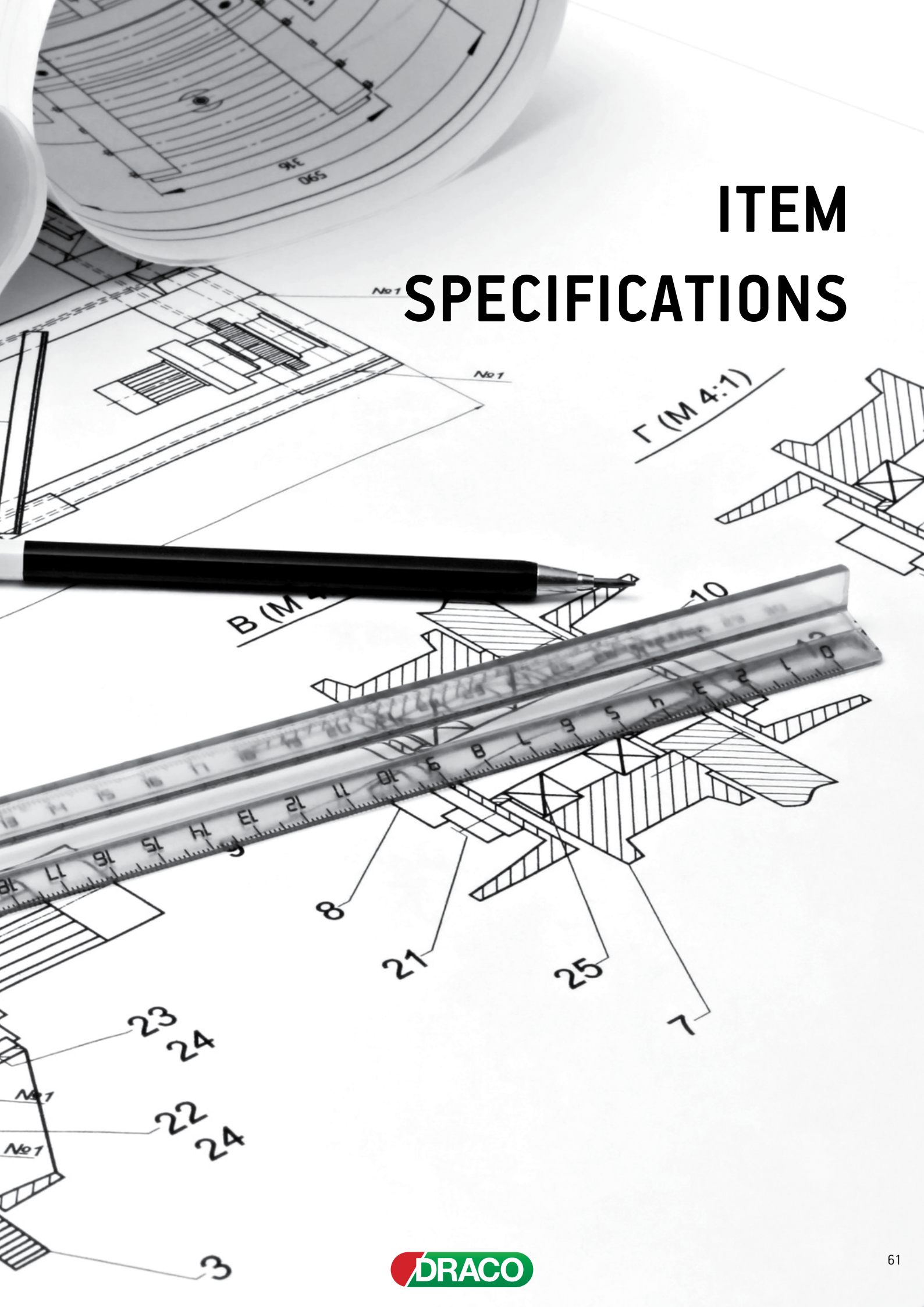

## 4.0.1

## PREPARATION

**Structural strengthening and seismic retrofitting of reinforced concrete structures and confinement of concrete elements subjected to compression and combined bending and axial load by using highly resistant carbon fibre fabrics and plates and composite materials with polymeric matrix (FRP).**

## REINFORCED CONCRETE PREPARATION

**SUBSTRATE PREPARATION AND CLEANING** - The substrate should be properly cleaned by removing all loose, damaged and crumbling parts of concrete, by power chiselling or hydro-scarifying, taking care not to damage the structures. Remove stains, efflorescences, residues and any previous restoration work if irretrievably damaged or deteriorated.

The surface must be rough and even to promote adhesion between the resin and the substrate. Remove any rust or debris from exposed reinforcement bars by sandblasting or by brushing until achieving bare metal finish. Hydrosandblasting is not required if the surface has been prepared by hydroscarifying

**REINFORCEMENT BARS PROTECTION** - After cleaning, treat the reinforcement bars by brush, applying two coats of DRACOSTEEL, the alkalizing treatment providing protection against corrosion.

**RESTORATION** - Clean the surface with compressed air or pressure washer to remove all residues from the concrete substrate cleaning and saturate the surface with pressurized water. Before carrying out repairs, excess water must be completely evaporated.

Structural repair of concrete using:

**FLUECO 40 T:** Thixotropic, fibre-reinforced mortar with shrinkage compensation and high resistance for structural restoration in aggressive environments. For layers up to 5 cm thick without electro-welded mesh.

The mortar should be mixed by adding water according to the mixing ratio specified in the technical data sheet, till getting a well-blended and lump-free mix. To prepare small quantities of product use a suitable vessel or container observing the suggested mixing ratio. In this case, it is recommended the use of a low-speed mechanical stirrer to avoid dragging air into the mix.

**APPLICATION** - The mortar should be applied by trowel or by spraying on clean surfaces roughened with 5-mm scratches and saturated with water as indicated in the paragraph above. In the presence of thick lifts that exceed the specified thickness, place an electro-welded mesh of adequate size, as defined by the designer. In order to reduce micro-cracking phenomenon caused by plastic shrinkage, it is recommended to smooth mortar once it has hardened with a damp sponge trowel.

**CURING** - To ensure a correct curing even in dry climate or when surfaces are exposed to excessive wind or sunlight, it is recommended to protect surfaces against the rapid evaporation of mix water by keeping the surfaces wet (humid curing) or by using the curing compound PROBETON CURING N.

## PREPARATION

**Structural strengthening and seismic retrofitting of masonry structures and confinement of masonry elements subjected to compression and combined bending and axial load by using highly resistant carbon fibre fabrics and plates and composite materials with polymeric matrix (FRP).**

### MASONRY PREPARATION

**SUBSTRATE PREPARATION AND CLEANING** - The substrate should be properly cleaned by removing all loose, damaged and crumbling parts. The surface shall be cleaned by brushing and dedusted. Remove stains, efflorescences, plaster residues and any previous restoration work if irretrievably damaged or deteriorated.

**RESTORATION** - In the presence of uneven masonries and depending on the state of degradation, restoration interventions to the internal continuity of the elements should be planned before carrying out reinforcing works.

**1) Fissures and microcracks that break the masonry continuity:** sealing by mortar or resin injections.

Drilling of the injection holes at the mortar joints, better if inclined. Diameter, depth and centre to centre distance will be defined during the design phase. Injectors positioning and fixing with mortar, grouting of cracks and joints with quick-setting mortar. Low-pressure injection of mortar or resin.

**2) Substantial cracks in structures subject to high compressive stresses:** reinforced seams of the masonry.

Drilling of the holes for the housing of bars and low-pressure injection with **DRACOFLOW** anchoring fluid grout of DRACO Italiana SpA. Any leak of fluid grout will be sealed by applying the quick-setting binder **HYDROPLUG** of DRACO Italiana SpA. Insertion of steel bars with improved adhesion and filling of the hole up to saturation with **DRACOFLOW** anchoring fluid grout of DRACO Italiana SpA. Final sealing of the hole with **FLUECO BLITZ** of DRACO Italiana SpA.

**3) Rubble masonry or discontinuous masonry:** Injections of binding mixtures up to saturation of cavities.

**4) Stone or brick elements which are unstable due to degraded joints:** repointing of the joints.

Removal of the joints and rendering with **ARMOLIME TA** of DRACO Italiana SpA, the breathable mortar for bedding and repointing masonry. Carefully fill all the empty spaces and press the mortar into the joint (pointing) so that the mix penetrates uniformly.

**5) If the masonry continuity is seriously damaged, its restoration should be considered and implemented through the like-for-like technique or, in extreme cases, through partial rebuilding of the walls.**

#### PREPARATION OF THE GROOVES FOR THE HOUSING OF FABRICS

To implement the grooves for the housing of **ARMOSHIELD C** fabrics, it's possible to choose between several possibilities: **FLUECO 80 T2** of DRACO Italiana SpA, the two-component thixotropic fibre-reinforced mortar with low modulus of elasticity; **FLUECO 40 T** of DRACO Italiana SpA, the nanopolymer thixotropic fibre-reinforced mortar with high resistance for structural repairing.

**CURING** - To ensure a correct curing even in dry climate or when surfaces are exposed to excessive wind or sunlight, it is recommended to protect surfaces against the rapid evaporation of mix water by keeping the surfaces wet (humid curing) or by using the curing compound **PROBETON CURING N**.

## 4.1

## STRENGTHENING OF STRUCTURAL ELEMENTS WITH CARBON FIBRE FABRICS

**Structural strengthening, seismic retrofitting and confinement of elements subjected to compression and combined bending and axial load by using highly resistant unidirectional, bidirectional and quadriaxial carbon fibre fabrics with high or very high modulus of elasticity.**

### ARMOSHIELD C

Supply and installation of **ARMOSHIELD C - SHEET /B/QUADRAX** of Draco Italiana S.p.A, the very flat unidirectional fabrics made of carbon fibres and high-density FRP composite materials that show high modulus of elasticity and develop high mechanical strength. They should be used for the reinforcement, static repair and confinement of concrete and masonry elements subjected to compression and combined bending and axial load with no load increase. The fabrics should be laid by respecting the following procedure:

#### PREPARATION:

- Any edges should be rounded to a radius of curvature  $\geq 2\text{cm}$ .
- Substrate preparation: remove the surface fluid cement grout and any damaged parts, stains, efflorescences, dirt and dust as indicated above.
- Substrate smoothing: remove roughness and fill the cavities in the bonding area.

#### LAYING:

1) Apply the epoxy primer **ARMOPRIMER 100** of DRACO Italiana S.p.A. on dry substrate by brush or roller.

The epoxy primer **ARMOPRIMER 100** of DRACO Italiana S.p.A. must have the following features:

- Density of the mix:  $1.1 \text{ g/cm}^3$
- Brookfield viscosity (rotor 1 - rotations 10):  $300 \text{ mPa}\cdot\text{s}$
- Adhesion to concrete (after 7 days at  $+23^\circ\text{C}$ ):  $> 3 \text{ MPa}$  (substrate failure)

**Consumption:**  $200$  to  $300 \text{ g/m}^2$  per coat depending on the porosity and irregularities of the substrate.

2) Skim the substrate and apply the structural epoxy gel resin **ARMOFIX MTX** of DRACO Italiana S.p.A. on clean and dry surface by spatula. Skimming is necessary on irregular or non-planar surfaces having surface unevenness  $> 5 \text{ mm}$ . Skimming must be performed after the primer touch dry period has elapsed and in any case within 16 hours, by using the epoxy adhesive **ARMOFIX MTX** of DRACO Italiana S.p.A. applied by spatula or trowel.



**ARMOFIX MTX** of DRACO Italiana S.p.A., the epoxy adhesive for the impregnation of fabrics, must have the following features (compliant with the minimum requirements of EN 1504-4):

FEATURES	PERFORMANCE	TEST METHOD
Ash content from direct calcination	2%	UNI EN ISO 3451-1
TGA DSC (Thermogravimetry)	+83°C	UNI EN ISO 11358
Pot Life	40'	UNI EN ISO 9514
Compressive strength	90 MPa	UNI EN 12190
Flexural modulus of elasticity	3100 MPa	UNI EN ISO 178
Shear strength	20,3 MPa	UNI EN 12188
Open time	40'	UNI EN 12189
Compressive modulus of elasticity	3200 MPa	UNI EN 13412
Glass transition temperature	83°C	UNI EN 12614
Coefficient of thermal expansion	$25 \times 10^{-6}/K$	UNI EN 1770
Dry shrinkage	0,03%	UNI EN 12617-1
Suitability for injection	Split concrete	UNI EN 12618-2
Adhesion	Cohesive fracture concrete	UNI EN 12636
Shear durability after humidity and thermal exposure	Break concrete	UNI EN 13733

#### Consumptions:

Skimming: 1.4 - 1.6 kg/m<sup>2</sup> per mm of thickness

Bonding and impregnation of the fabrics - Average total thickness of about 1 mm:

approx. 1.1 kg/m<sup>2</sup> for a fabric layer of 300 g/m<sup>2</sup> - approx. 1.5 kg/m<sup>2</sup> for a fabric layer of 600 g/m<sup>2</sup>.

**3)** Apply **ARMOSHIELD C** of DRACO Italiana S.p.A. carbon fibre fabric over the fresh resin coat and impregnate with **ARMOROLLER** of DRACO Italiana S.p.A. spiked roller. Apply the second coat of adhesive after about 1 hour. The size and type of fabric to be used will be determined depending on the project requirements; it will be possible to choose between different weights and widths according to the type of intervention.

The available versions of carbon fibre fabric are:

- **ARMOSHIELD C-SHEET** - unidirectional fabric - weight 300 or 600 g/m<sup>2</sup> - width of 10, 20, 40 and 60 cm.
- **ARMOSHIELD C-B** - bidirectional fabric - weight 320 g/m<sup>2</sup> - width of 10, 20 and 50 cm.
- **ARMOSHIELD C-QUADRAX** - quadriaxial fabric - weight 380 g/m<sup>2</sup> - width of 31.5 - 42 cm.

- One or more layers may be applied depending on the project characteristics, by repeating the application procedure described above.

## 4.1

The carbon fibre fabrics must have the following features:

**- ARMOSHIELD C - SHEET**

*Very flat unidirectional fabric made of highly resistant carbon fibres for structural strengthening*

FEATURES OF ARMOSHIELD C - B FABRIC				
MODULUS OF ELASTICITY (GPa)	240		390	
WEIGHT (g/m <sup>2</sup> )	300	600	300	600
EQUIVALENT THICKNESS OF DRY FABRIC (mm)	0,164	0,328	0,165	0,33
TENSILE STRENGTH (MPa)	> 4900	> 4900	4410	4410
RESISTANT AREA PER UNIT WIDTH (mm <sup>2</sup> /m)	164	328	165	330
MAXIMUM LOAD PER UNIT WIDTH (kN/m)	> 800	>1600	> 700	>1400
ELONGATION AT BREAKAGE (%)	2,1		1,2	
AVAILABLE HEIGHTS (cm)	10-20-40-60			
ADHESION TO CONCRETE (MPa)	> 3 (break of support)			

**- ARMOSHIELD C - B**

*Bidirectional fabric made of highly resistant carbon fibres for structural strengthening*

FEATURES OF ARMOSHIELD C - B FABRIC	
MODULUS OF ELASTICITY (GPa)	250
WEIGHT (g/m <sup>2</sup> )	320
EQUIVALENT THICKNESS OF DRY FABRIC (mm)	0,164
TENSILE STRENGTH (MPa)	4980
RESISTANT AREA PER UNIT WIDTH (mm <sup>2</sup> /m)	163,6
MAXIMUM LOAD PER UNIT WIDTH (kN/m)	804,12
ELONGATION AT BREAKAGE (%)	2
AVAILABLE HEIGHTS (cm)	10-20-50
ADHESION TO CONCRETE (MPa)	> 3 (break concrete)

**- ARMOSHIELD C - QUADRAX***Quadriaxial fabric made of highly resistant carbon fibres for structural strengthening*

FEATURES OF ARMOSHIELD C - QUADRAX FABRIC		
MODULUS OF ELASTICITY (GPa)	235	240
WEIGHT (g/m <sup>2</sup> )	380	760
EQUIVALENT THICKNESS OF DRY FABRIC (mm)	0,052	0,105
TENSILE STRENGTH (MPa)	> 4900	> 4900
RESISTANT AREA PER UNIT WIDTH (mm <sup>2</sup> /m)	51,9	105,5
MAXIMUM LOAD PER UNIT WIDTH (kN/m)	> 260	> 500
ELONGATION AT BREAKAGE (%)	2,1	2
AVAILABLE HEIGHTS (cm)	31,5-42	31,75-62,5
ADHESION TO CONCRETE (MPa)	> 3 (break concrete)	> 3 (break concrete)

**4)** Apply the protective coating over the reinforcing areas or spread quartz sand for any finishing plaster. The coating must be applied after the epoxy systems have completely hardened (1-2 days, depending on the temperature).

## 4.2

## STRENGTHENING OF STRUCTURAL ELEMENTS WITH CARBON FIBRE PULTRUDED PLATES

**Structural strengthening and seismic retrofitting of elements subjected to compression and combined bending and axial load by using highly resistant carbon fibre pultruded plates.**

### ARMOSHIELD CFK LAMELLE

Supply and installation of **ARMOSHIELD CFK LAMELLE** of Draco Italiana S.p.A, the carbon fibre pultruded plates pre-impregnated with high-density epoxy resin that shows high mechanical strength. They should be used for the reinforcement, static repair and plating of concrete and masonry elements subjected to compression and combined bending and axial load with no load increase. The plates should be laid by respecting the following procedure:

#### PREPARATION:

- Substrate preparation: remove the surface fluid cement grout and any damaged parts, stains, efflorescences, dirt and dust as indicated above.
- Substrate smoothing: removing of roughness and filling of cavities in the bonding area.

#### LAYING:

The plates should be laid by respecting the following procedure:

- 1) Cut the plate to the size needed according to the project requirements. Remove the protective film, if any, or clean both sides of the plate with **ARMOCLEANER CFK**.
- 2) Apply the epoxy primer **ARMOPRIMER 100** of DRACO Italiana S.p.A. on dry substrate by brush or roller.

The epoxy primer **ARMOPRIMER 100** of DRACO Italiana S.p.A. must have the following features:

- Density of the mix: 1.1 g/cm<sup>3</sup>
- Brookfield viscosity (rotor 1 - rotations 10): 300 mPa·s
- Adhesion to concrete (after 7 days at +23°C): > 3 MPa (substrate failure)

**Consumption:** 200 to 300 g/m<sup>2</sup> per coat depending on the porosity and irregularities of the substrate.

- 3) Skim the substrate and apply the structural epoxy resin **ARMOFIX MTL** of DRACO Italiana S.p.A. by spatula.

Skimming is necessary on irregular or non-planar surfaces having surface unevenness > 5 mm. Skimming must be performed after the primer touch dry period has elapsed and in any case within 16 hours, by using the epoxy bonding adhesive **ARMOFIX MTL** of DRACO Italiana S.p.A. applied by spatula or trowel. Apply a first coat of **ARMOFIX MTL** bonding resin of DRACO Italiana S.p.A. by spatula on the clean and dry surface and on the side of the plate to be bonded to the substrate, ranging in thickness from 1 to 3 mm.

**ARMOFIX MTL** of DRACO of Italiana S.p.A., the epoxy adhesive for the bonding of pultruded plates, must have the following features (compliant with the minimum requirements of EN 1504-4):

FEATURES	PERFORMANCE	TEST METHOD
TGA DSC (Thermogravimetry)	67°C	UNI EN ISO 11358
Pot Life	90'	UNI EN ISO 9514
Compressive strength	> 50 MPa	UNI EN 12190
Flexural modulus of elasticity	6100 MPa	UNI EN ISO 178
Shear strength	19,4 MPa	UNI EN 12188
Open time	120'	UNI EN 12189
Compressive modulus of elasticity	6500 MPa	UNI EN 13412
Glass transition temperature	67°C	UNI EN 12614
Coefficient of thermal expansion	$18 \times 10^{-6}/K$	UNI EN 1770
Dry shrinkage	0,04%	UNI EN 12617-1
Suitability for injection	Split concrete	UNI EN 12618-2
Adhesion	Cohesive fracture concrete	UNI EN 12636
Shear durability after humidity and thermal exposure	Break concrete	UNI EN 13733

#### Consumptions:

Skimming: 150 g/m per mm of thickness Recommended thickness 1-3 mm

Plate bonding:

- 150-200 g/m for the bonding of 5-cm plate
- 240-320 g/m for the bonding of 8-cm plate
- 300-400 g/m for the bonding of 10-cm plate
- 360-480 g/m for the bonding of 12-cm plate

**3)** Apply **ARMOSHIELD CFK** of Draco Italiana S.p.A., the carbon fibre pultruded plates, over the fresh resin coat by exerting a slight pressure over their entire length, either by hand or by hard rubber roller to remove air bubbles that may have formed. Remove excess adhesive leaked from the plate sides.

- One or more layers may be applied depending on the project characteristics, by repeating the application procedure described above.

The carbon fibre pultruded plates **ARMOSHIELD CFK** of Draco Italiana S.p.A. must have the following features:

FEATURES										
Density (g/cm <sup>3</sup> )	1,6									
Fibre content (%)	68%									
Tensile modulus of elasticity (GPa)	160					210				
Thickness (mm)	1,2 (2pp)			1,4			1,4			
Width (mm)	50	80	100	50	80	100	50	80	100	120
Resistant section (mm <sup>2</sup> )	60	96	120	70	112	140	70	112	140	168
Tensile strength (MPa)	> 2400									
Elongation at breakage (%)	1,36%					0,95%				

**4)** Apply the protective coating over the reinforcing areas or spread quartz sand for any finishing plaster. The coating must be applied after the epoxy systems have completely hardened (1-2 days, depending on the temperature).

## 4.3

## STRENGTHENING OF STRUCTURAL ELEMENTS WITH PULTRUDED CARBON FIBRE FABRICS AND PLATES

**Structural strengthening and seismic retrofitting of elements subjected to compression, combined bending and axial load and shear stress by using highly resistant pultruded plates and carbon fibre fabrics**

Supply and installation of **ARMOSHIELD CFK LAMELLE** of Draco Italiana S.p.A, the carbon fibre pultruded plates pre-impregnated with high-density epoxy resin that shows high mechanical strength, and **ARMOSHIELD C** of Draco Italiana S.p.A., the high resistance carbon fibre fabrics. They should be used for the reinforcement, static repair and plating of concrete and masonry elements subjected to compression and combined bending and axial load with no load increase. The plates and fabrics should be laid by respecting the following procedure:

### PREPARATION:

- Substrate preparation: remove the surface fluid cement grout and any damaged parts, stains, efflorescences, dirt and dust as indicated above.
- Substrate smoothing: remove roughness and fill the cavities in the bonding area.

### LAYING:

1) Apply the epoxy primer **ARMOPRIMER 100** of DRACO Italiana S.p.A. on dry substrate by brush or roller.

The epoxy primer **ARMOPRIMER 100** of DRACO Italiana S.p.A. must have the following features:

- Density of the mix: 1.1 g/cm<sup>3</sup>
- Brookfield viscosity (rotor 1 - rotations 10): 300 mPa·s
- Adhesion to concrete (after 7 days at +23°C): > 3 MPa (substrate failure)

**Consumption:** 200 to 300 g/m<sup>2</sup> per coat depending on the porosity and irregularities of the substrate.

2) Skim the substrate and apply the structural epoxy resin **ARMOFIX MTL** of DRACO Italiana S.p.A. by spatula.

Skimming is necessary on irregular or non-planar surfaces having surface unevenness > 5 mm. Skimming must be performed after the primer touch dry period has elapsed and in any case within 16 hours, by using the epoxy bonding adhesive **ARMOFIX MTL** of DRACO Italiana S.p.A. applied by spatula or trowel. Apply a first coat of **ARMOFIX MTL** bonding resin of DRACO Italiana S.p.A. by spatula on the clean and dry surface and on the side of the plate to be bonded to the substrate, ranging in thickness from 1 to 3 mm.

**ARMOFIX MTL** of DRACO Italiana S.p.A., the epoxy adhesive for the bonding of pultruded plates, must have the following features (compliant with the minimum requirements of EN 1504-4):

FEATURES	PERFORMANCE	TEST METHOD
TGA DSC (Thermogravimetry)	67°C	UNI EN ISO 11358
Pot Life	90'	UNI EN ISO 9514
Compressive strength	55 MPa	UNI EN 12190
Flexural modulus of elasticity	6100 MPa	UNI EN ISO 178
Shear strength	19,4 MPa	UNI EN 12188
Open time	120'	UNI EN 12189
Compressive modulus of elasticity	6500 MPa	UNI EN 13412
Glass transition temperature	67°C	UNI EN 12614
Coefficient of thermal expansion	$18 \times 10^{-6} / K$	UNI EN 1770
Dry shrinkage	0,04%	UNI EN 12617-1
Suitability for injection	Split concrete	UNI EN 12618-2
Adhesion	Cohesive fracture concrete	UNI EN 12636
Shear durability after humidity and thermal exposure	Break concrete	UNI EN 13733

#### Consumptions:

Skimming: 150 g/m per mm of thickness Recommended thickness 1-3 mm

Plate bonding:

- 150-200 g/m for the bonding of 5-cm plate
- 240-320 g/m for the bonding of 8-cm plate
- 300-400 g/m for the bonding of 10-cm plate
- 360-480 g/m for the bonding of 12-cm plate

**3)** Apply **ARMOSHIELD CFK** of Draco Italiana S.p.A., the carbon fibre pultruded plates, over the fresh resin coat by exerting a slight pressure over their entire length, either by hand or by hard rubber roller to remove air bubbles that may have formed. Remove excess adhesive leaked from the plate sides.

- One or more layers may be applied depending on the project characteristics, by repeating the application procedure described above.

The carbon fibre pultruded plates **ARMOSHIELD CFK** of Draco Italiana S.p.A. must have the following features:

FEATURES										
Density (g/cm <sup>3</sup> )	1,6									
Fibre content (%)	68%									
Tensile modulus of elasticity (GPa)	160					210				
Thickness (mm)	1,2 (2pp)			1,4			1,4			
Width (mm)	50	80	100	50	80	100	50	80	100	120
Resistant section (mm <sup>2</sup> )	60	96	120	70	112	140	70	112	140	168
Tensile strength (MPa)	> 2400					> 2400				
Elongation at breakage (%)	1,36%					0,95%				

## 4.3

5) Apply the structural epoxy gel resin **ARMOFIX MTX** of DRACO Italiana S.p.A. on the clean and dry surface by spatula to promote the subsequent laying of the fabrics. The adhesive must be applied on the plates and on the areas identified by the designer.

**ARMOFIX MTX** of DRACO Italiana S.p.A., the epoxy adhesive for the impregnation of fabrics, must have the following features (compliant with the minimum requirements of EN 1504-4):

FEATURES	PERFORMANCE	TEST METHOD
Ash content from direct calcination	2%	UNI EN ISO 3451-1
TGA DSC (Thermogravimetry)	+83°C	UNI EN ISO 11358
Pot Life	40'	UNI EN ISO 9514
Compressive strength	90 MPa	UNI EN 12190
Flexural modulus of elasticity	3100 MPa	UNI EN ISO 178
Shear strength	20,3 MPa	UNI EN 12188
Open time	40'	UNI EN 12189
Compressive modulus of elasticity	3200 MPa	UNI EN 13412
Glass transition temperature	83°C	UNI EN 12614
Coefficient of thermal expansion	$25 \times 10^{-6}/K$	UNI EN 1770
Dry shrinkage	0,03%	UNI EN 12617-1
Suitability for injection	Split concrete	UNI EN 12618-2
Adhesion	Cohesive fracture concrete	UNI EN 12636
Shear durability after humidity and thermal exposure	Break concrete	UNI EN 13733

6) Apply **ARMOSHIELD C** of DRACO Italiana S.p.A. carbon fibre fabric over the fresh resin coat and impregnate with **ARMOROLLER** of DRACO Italiana S.p.A. spiked roller. Apply the second coat of adhesive after about 1 hour. The size and type of fabric to be used will be determined depending on the project requirements; it will be possible to choose between different weights and widths according to the type of intervention.

The available versions of carbon fibre fabric are:

- **ARMOSHIELD C-SHEET** - unidirectional fabric - weight 300 or 600 g/m<sup>2</sup> - width of 10, 20, 40 and 60 cm.
- **ARMOSHIELD C-B** - bidirectional fabric - weight 320 g/m<sup>2</sup> - width of 10, 20 and 50 cm.
- **ARMOSHIELD C-QUADRAX** - quadriaxial fabric - weight 380 g/m<sup>2</sup> - width of 31.5 - 42 cm.

- One or more layers may be applied depending on the project characteristics, by repeating the application procedure described above.



The carbon fibre fabrics must have the following features:

#### - ARMOSHIELD C - SHEET

*Very flat unidirectional fabric made of highly resistant carbon fibres for structural strengthening*

FEATURES OF ARMOSHIELD C - B FABRIC			
MODULUS OF ELASTICITY (GPa)	240		390
WEIGHT (g/m <sup>2</sup> )	300	600	300 600
EQUIVALENT THICKNESS OF DRY FABRIC (mm)	0,164	0,328	0,165 0,33
TENSILE STRENGTH (MPa)	> 4900	> 4900	4410 4410
RESISTANT AREA PER UNIT WIDTH (mm <sup>2</sup> /m)	164	328	165 330
MAXIMUM LOAD PER UNIT WIDTH (kN/m)	> 800	>1600	> 700 >1400
ELONGATION AT BREAKAGE (%)	2,1		1,2
AVAILABLE HEIGHTS (cm)	10-20-40-60		
ADHESION TO CONCRETE (MPa)	> 3 (break of support)		

#### - ARMOSHIELD C - B

*Bidirectional fabric made of highly resistant carbon fibres for structural strengthening*

FEATURES OF ARMOSHIELD C - B FABRIC	
Modulus of elasticity (GPa)	250
Weight (g/m <sup>2</sup> )	320
Equivalent thickness of dry fabric (mm)	0,164
Tensile strength (MPa)	4980
Resistant area per unit width (mm <sup>2</sup> /m)	163,6
Maximum load per unit width (kN/m)	804,12
Elongation at breakage (%)	2
Available heights (cm):	10-20-50
Adhesion to concrete (MPa)	> 3 (break concrete)

#### - ARMOSHIELD C - QUADRAX

*Quadriaxial fabric made of highly resistant carbon fibres for structural strengthening*

FEATURES OF ARMOSHIELD C - QUADRAX FABRIC		
MODULUS OF ELASTICITY (GPa)	235	240
WEIGHT (g/m <sup>2</sup> )	380	760
EQUIVALENT THICKNESS OF DRY FABRIC (mm)	0,052	0,105
TENSILE STRENGTH (MPa)	> 4900	> 4900
RESISTANT AREA PER UNIT WIDTH (mm <sup>2</sup> /m)	51,9	105,5
MAXIMUM LOAD PER UNIT WIDTH (kN/m)	> 260	> 500
ELONGATION AT BREAKAGE (%)	2,1	2
AVAILABLE HEIGHTS (cm)	31,5-42	31,75-62,5
ADHESION TO CONCRETE (MPa)	> 3 (break concrete)	> 3 (break concrete)

7) Apply the protective coating over the reinforcing areas or spread quartz sand for any finishing plaster. The coating must be applied after the epoxy systems have completely hardened (1-2 days, depending on the temperature).

## 4.4

## STRUCTURAL REINFORCEMENT AND STRENGTHENING OF WOODEN STRUCTURES

**Structural strengthening of wooden elements subjected to bending by using highly resistant carbon fibre fabrics and composites materials with polymer matrix (FRP)**

### SUBSTRATE PREPARATION

**SUBSTRATE PREPARATION AND CLEANING** - The substrate should be properly cleaned by removing all loose, damaged and crumbling parts. The surface shall be cleaned and dedusted. Remove stains, efflorescences, plaster residues, varnishes and any previous restoration work if irretrievably damaged or deteriorated.

In the case of external application, check the flatness of the laying surface and, where appropriate, smooth it by planing and remove any coats or treatments on the surface laying of the reinforcement with a flap disc. Fill any longitudinal cracks with an elastic adhesive that does not prevent the seasonal movement of the wood while ensuring the necessary adhesion between the reinforcement and the substrate.

#### LAYING:

The plates should be laid by respecting the following procedure:

- 1) Cut the plate to the size needed according to the project requirements. Remove the protective film, if any, or clean both sides of the plate with **ARMOCLEANER CFK** of DRACO Italiana S.p.A.
- 2) Apply the epoxy primer **ARMOPRIMER 100** of DRACO Italiana S.p.A. on dry substrate by brush.

The epoxy primer **ARMOPRIMER 100** of DRACO Italiana S.p.A. must have the following features:

- Density of the mix: 1.1 g/cm<sup>3</sup>
- Brookfield viscosity (rotor 1 - rotations 10): 300 mPa·s
- Adhesion to concrete (after 7 days at +23°C): > 3 MPa (substrate failure)

**Consumption:** 200÷300 g/m<sup>2</sup> per coat depending on the porosity and irregularities of the substrate.

- 3) Apply the structural epoxy resin **ARMOFIX MTX** of DRACO Italiana S.p.A. by spatula. Apply a first coat of **ARMOFIX MTX** bonding resin of DRACO Italiana S.p.A. by spatula on the clean and dry surface and on the side of the plate to be bonded to the substrate, ranging in thickness from 1 to 3 mm.

**ARMOFIX MTX** of DRACO Italiana S.p.A., the epoxy adhesive for the impregnation of fabrics, must have the following features (compliant with the minimum requirements of EN 1504-4):

FEATURES	PERFORMANCE	TEST METHOD
Ash content from direct calcination	2%	UNI EN ISO 3451-1
TGA DSC (Thermogravimetry)	+83°C	UNI EN ISO 11358
Pot Life	40'	UNI EN ISO 9514
Compressive strength	90 MPa	UNI EN 12190
Flexural modulus of elasticity	3100 MPa	UNI EN ISO 178
Shear strength	20,3 MPa	UNI EN 12188
Open time	40'	UNI EN 12189
Compressive modulus of elasticity	3200 MPa	UNI EN 13412
Glass transition temperature	83°C	UNI EN 12614
Coefficient of thermal expansion	25x10 <sup>-6</sup> /K	UNI EN1770
Dry shrinkage	0,03%	UNI EN 12617-1
Suitability for injection	Split concrete	UNI EN12618-2
Adhesion	Cohesive fracture concrete	UNI EN12636
Shear durability after humidity and thermal exposure	Break concrete	UNI EN 13733

#### Consumptions:

Skimming: 1.4 - 1.6 kg/m<sup>2</sup> per mm of thickness

Bonding and impregnation of the fabrics - Average total thickness of about 1 mm:

approx. 1.1 kg/m<sup>2</sup> for a fabric layer of 300 g/m<sup>2</sup> - approx. 1.5 kg/m<sup>2</sup> for a fabric layer of 600 g/m<sup>2</sup>.

**3)** Apply **ARMOSHIELD C** of DRACO Italiana S.p.A. carbon fibre fabric over the fresh resin coat and impregnate with **ARMOROLLER** of DRACO Italiana S.p.A. spiked roller. Apply the second coat of adhesive after about 1 hour. The size and type of fabric to be used will be determined depending on the project requirements; it will be possible to choose between different weights and widths according to the type of intervention.

- **ARMOSHIELD C-SHEET** - unidirectional fabric - weight 300 or 600 g/m<sup>2</sup> - width of 10, 20, 40 and 60 cm.
- **ARMOSHIELD C-B** - bidirectional fabric - weight 320 g/m<sup>2</sup> - width of 10, 20 and 50 cm.
- **ARMOSHIELD C-QUADRAX** - quadriaxial fabric - weight 380 g/m<sup>2</sup> - width of 31.5 - 42 cm.

- One or more layers may be applied depending on the project characteristics, by repeating the application procedure described above.

The carbon fibre fabrics must have the following features:

#### - ARMOSHIELD C - SHEET

**Very flat unidirectional fabric made of highly resistant carbon fibres for structural strengthening**

FEATURES OF ARMOSHIELD C - SHEET				
MODULUS OF ELASTICITY (GPa)	240		390	
WEIGHT (g/m <sup>2</sup> )	300	600	300	600
EQUIVALENT THICKNESS OF DRY FABRIC (mm)	0,164	0,328	0,165	0,33
TENSILE STRENGTH (MPa)	> 4900	> 4900	4410	4410
RESISTANT AREA PER UNIT WIDTH (mm <sup>2</sup> /m)	164	328	165	330
MAXIMUM LOAD PER UNIT WIDTH (kN/m)	> 800	>1600	> 700	>1400
ELONGATION AT BREAKAGE (%)	2,1		1,2	
AVAILABLE HEIGHTS (cm)	10-20-40-60			
ADHESION TO CONCRETE (MPa)	> 3 (break concrete)			

## 4.5

## STRUCTURAL REINFORCEMENT AND STRENGTHENING OF WOODEN STRUCTURES

### Structural strengthening of wooden elements subjected to bending by using highly resistant carbon fibre plates and composites materials with polymer matrix (FRP)

Supply and installation of **ARMOSHIELD CFK** of Draco Italiana S.p.A, the carbon fibre pultruded plates pre-impregnated with high-density epoxy resin that shows high mechanical strength. They should be used for the strengthening of wooden elements subjected to bending with no load increase.

### SUBSTRATE PREPARATION

**SUBSTRATE PREPARATION AND CLEANING** - The substrate should be properly cleaned by removing all loose, damaged and crumbling parts. The surface shall be cleaned and dedusted. Remove stains, efflorescences, plaster residues, varnishes and any previous restoration work if irretrievably damaged or deteriorated.

**In the case of external application:** check the flatness of the laying surface and, where appropriate, smooth it by planing and remove any coats or treatments on the surface laying of the reinforcement with a flap disc. Fill any longitudinal cracks with an elastic adhesive that does not prevent the seasonal movement of the wood while ensuring the necessary adhesion between the reinforcement and the substrate.

**In the case of intervention with plates housed in slot:** Mill the beam by performing a longitudinal cut with proper depth and length depending on the plate size (width: about 2 mm; depth: 30 - 45 mm). The features of the plate to be used should be determined during the design stage. Later, thoroughly clean the slot from dust and residues by vacuum cleaner or brush. Cleaning should be carried out in a dry environment. Protect the surface surrounding the slot from the subsequent adhesive application by installing an adhesive tape along its perimeter.

#### LAYING:

The plates should be laid by respecting the following procedure:

- 1) Cut the plate to the size needed according to the project requirements. Remove the protective film, if any, or clean both sides of the plate with **ARMOCLEANER CFK** of DRACO Italiana S.p.A.
- 2) Application of the epoxy primer **ARMOPRIMER 100** of DRACO Italiana S.p.A. on dry substrate by brush or by injection in case of plate housing into the slot.

The epoxy primer **ARMOPRIMER 100** of DRACO Italiana S.p.A. must have the following features:

- Density of the mix: 1.1 g/cm<sup>3</sup>
- Brookfield viscosity (rotor 1 - rotations 10): 300 mPa·s
- Adhesion to concrete (after 7 days at +23°C): > 3 MPa (substrate failure)

**Consumption:** 200÷300 g/m<sup>2</sup> per coat depending on the porosity and irregularities of the substrate.

- 3) Apply the structural epoxy adhesive **ARMOFIX MTX** of DRACO Italiana S.p.A. by spatula. Apply a first coat of **ARMOFIX MTX** bonding resin of DRACO Italiana S.p.A. by spatula on the clean and dry surface and on the side of the plate to be bonded to the substrate, ranging in thickness from 1 to 3 mm; for interventions with plates housed in slots, inject the resin ARMOFIX MTX of DRACO Italiana S.p.A. into it, by filling it by 3/4.

**ARMOFIX MTX** of DRACO of Italiana S.p.A., the epoxy adhesive for the bonding of pultruded plates, must have the following features (compliant with the minimum requirements of EN 1504-4):

FEATURES	PERFORMANCE	TEST METHOD
Ash content from direct calcination	2%	UNI EN ISO 3451-1
TGA DSC (Thermogravimetry)	+83°C	UNI EN ISO 11358
Pot Life	40'	UNI EN ISO 9514
Compressive strength	90 MPa	UNI EN 12190
Flexural modulus of elasticity	3100 MPa	UNI EN ISO 178
Shear strength	20,3 MPa	UNI EN 12188
Open time	40'	UNI EN 12189
Compressive modulus of elasticity	3200 MPa	UNI EN 13412
Glass transition temperature	83°C	UNI EN 12614
Coefficient of thermal expansion	25x10 <sup>-6</sup> /K	UNI EN1770
Dry shrinkage	0,03%	UNI EN 12617-1
Suitability for injection	Split concrete	UNI EN12618-2
Adhesion	Cohesive fracture concrete	UNI EN12636
Shear durability after humidity and thermal exposure	Break concrete	UNI EN 13733

#### Consumptions:

Skimming: 1.4 - 1.6 kg/m<sup>2</sup> per mm of thickness

Bonding and impregnation of the fabrics - Average total thickness of about 1 mm:

approx. 1.1 kg/m<sup>2</sup> for a fabric layer of 300 g/m<sup>2</sup> - approx. 1.5 kg/m<sup>2</sup> for a fabric layer of 600 g/m<sup>2</sup>.

4) Apply **ARMOSHIELD CFK** of Draco Italiana S.p.A, the carbon fibre pultruded plates, over the fresh resin coat by exerting a slight pressure over their entire length, either by hand or by hard rubber roller to remove air bubbles that may have formed. Remove excess adhesive leaked from the plate sides. In case of housed plates, insert these and remove the excess adhesive. Fill the slot by grouting with the same bonding resin mixed with the sawdust produced during the milling, or seal with a slat cut to the size needed.

- One or more layers may be applied depending on the project characteristics, by repeating the application procedure described above.

The carbon fibre pultruded plates **ARMOSHIELD CFK** of Draco Italiana S.p.A. must have the following features:

FEATURES										
Density (g/cm <sup>3</sup> )	1,6									
Fibre content (%)	68%									
Tensile modulus of elasticity (GPa)	160					210				
Thickness (mm)	1,2 (2pp)			1,4			1,4			
Width (mm)	50	80	100	50	80	100	50	80	100	120
Resistant section (mm <sup>2</sup> )	60	96	120	70	112	140	70	112	140	168
Tensile strength (MPa)	> 2400					> 2400				
Elongation at breakage (%)	1,36%					0,95%				

5) Apply the protective coating over the reinforcing areas or spread quartz sand for any finishing plaster. The coating must be applied after the epoxy systems have completely hardened (1-2 days, depending on the temperature).

## 4.6

## STRENGTHENING OF STRUCTURAL ELEMENTS WITH CARBON FIBRE FABRICS

**Anchoring of structural reinforcements performed through carbon fibre fabrics using aramid connectors****ARMOGRIP**

Supply and installation of anchoring devices made of high-strength aramid fibres woven in bundles resulting in a hollow braid, in order to allow the interconnection of the reinforcements performed through carbon fabrics of ARMOSHIELD C line.

**ARRANGEMENT OF HOUSING HOLES**

Drill the holes with a diameter of 14-18 mm and with a depth of at least 12 cm depending on the connector size. The actual sizes will be evaluated on the basis of the size and type of substrate, as defined by the designer. Round the edges of the hole outer profile (minimum radius of 1cm), and remove dust and loose material by vacuum cleaner.

**PRIMING:**

**1)** Apply the epoxy primer **ARMOPRIMER 100** of DRACO Italiana S.p.A. inside the holes by brush or pipe cleaner. For particularly absorbent substrates you can apply a second coat of product.

The epoxy primer **ARMOPRIMER 100** of DRACO Italiana S.p.A. must have the following features:

- Density of the mix: 1.1 g/cm<sup>3</sup>
- Brookfield viscosity (rotor 1 - rotations 10): 300 mPa·s
- Adhesion to concrete (after 7 days at +23°C): > 3 MPa (substrate failure)

**Consumption:** 200÷300 g/m<sup>2</sup> per coat depending on the porosity and irregularities of the substrate.

**LAYING:**

**2)** Inject **ARMOFIX MT** (for horizontal application) or **ARMOFIX MTX** (for vertical application) inside the hole taking care to fill half of it; insert **ARMOGRIP** connector inside the hole. Proceed with the impregnation and filling of the connector cavity for its entire length with **ARMOFIX MT** or **ARMOFIX MTX**. The aramid connector portion which has not been impregnated and comes out of the hole (thread) should be opened like a fan and fixed to the surface surrounding the hole by resin impregnation. Take a portion of **ARMOSHIELD C** carbon fibre fabric of a size which enables the full covering of the thread and apply it over the first coat of resin while it is still fresh.

**ARMOFIX MT** of DRACO Italiana S.p.A., the epoxy adhesive for the bonding of pultruded plates, must have the following features (compliant with the minimum requirements of EN 1504-4):

FEATURES	PERFORMANCE	TEST METHOD
Ash content from direct calcination	0,5%	UNI EN ISO 3451-1
TGA DSC (Thermogravimetry)	+84°C	UNI EN ISO 11358
Pot life	40'	UNI EN ISO 9514
Compressive strength	60 MPa	UNI EN 12190
Flexural modulus of elasticity	3100 MPa	UNI EN ISO 178
Shear strength	19,4 MPa	UNI EN 12188
Open time	60'	UNI EN 12189
Compressive modulus of elasticity	3200 MPa	UNI EN 13412
Glass transition temperature	84°C	UNI EN 12614
Coefficient of thermal expansion	26x10 <sup>-6</sup> /K	UNI EN 1770
Dry shrinkage	0,04%	UNI EN 12617-1
Suitability for injection	Split concrete	UNI EN 12618-2
Adhesion	Cohesive fracture concrete	UNI EN 12636
Shear durability after humidity and thermal exposure	Break concrete	UNI EN 13733

**Consumptions:**

approx 1.1 kg/m<sup>2</sup> per mm of thickness

The epoxy adhesive for the impregnation of fabrics **ARMOFIX MTX** of DRACO Italiana S.p.A. must have the following features (compliant with the minimum requirements of EN 1504-4):

FEATURES	PERFORMANCE	TEST METHOD
Ash content from direct calcination	2%	UNI EN ISO 3451-1
TGA DSC (Thermogravimetry)	+83°C	UNI EN ISO 11358
Pot Life	40'	UNI EN ISO 9514
Compressive strength	90 MPa	UNI EN 12190
Flexural modulus of elasticity	3100 MPa	UNI EN ISO 178
Shear strength	20,3 MPa	UNI EN 12188
Open time	40'	UNI EN 12189
Compressive modulus of elasticity	3200 MPa	UNI EN 13412
Glass transition temperature	83°C	UNI EN 12614
Coefficient of thermal expansion	25x10 <sup>-6</sup> /K	UNI EN 1770
Dry shrinkage	0,03%	UNI EN 12617-1
Suitability for injection	Split concrete	UNI EN 12618-2
Adhesion	Cohesive fracture concrete	UNI EN 12636
Shear durability after humidity and thermal exposure	Break concrete	UNI EN 13733

**Consumptions:**

Skimming: 1.4 - 1.6 kg/m<sup>2</sup> per mm of thickness

Bonding and impregnation of the fabrics - Average total thickness of about 1 mm:

approx. 1.1 kg/m<sup>2</sup> for a fabric layer of 300 g/m<sup>2</sup> - approx. 1.5 kg/m<sup>2</sup> for a fabric layer of 600 g/m<sup>2</sup>.

- Where a finishing is envisaged, quartz sand should be applied over the fresh resin coat.

**ARMOGRIP** connectors must have the following performance characteristics:

ARMOGRIP CONNECTORS	
Diameter	12 mm
Strand tensile strength	2900 MPa
Modulus of elasticity	120 GPa
Elongation at breakage	2,5 %
Connector tensile strength	56 kN
Strand section	0,239 cm <sup>2</sup>
AVAILABLE SIZES	
20 cm thread	A10F20 (connector length 10 cm) A20F20 (connector length 20 cm) A30F20 (connector length 30 cm)
30 cm thread	A50F30 (connector length 50 cm)

## 4.7

## STRENGTHENING OF STRUCTURAL ELEMENTS WITH COMPOSITE MATERIALS WITH CARBON FIBRE FABRICS

**Anchoring and interconnection between structural reinforcements performed through carbon fibre fabrics using aramid connectors coupled with carbon bars**

### ARMOGRIP BC

Supply and installation of anchoring devices made of high-strength aramid fibres woven in bundles resulting in a hollow braid coupled with pultruded carbon bars, in order to allow the interconnection of the reinforcements performed through carbon fabrics of ARMOSHIELD C line.

#### ARRANGEMENT OF HOUSING HOLES

Drill the holes with a diameter of 14-18 mm and with a depth of at least 12 cm depending on the connector size. The actual sizes will be evaluated on the basis of the size and type of substrate, as defined by the designer. Round the edges of the hole outer profile (minimum radius of 1cm), and remove dust and loose material by vacuum cleaner.

#### PRIMING:

1) Apply the epoxy primer **ARMOPRIMER 100** of DRACO Italiana S.p.A. inside the holes by brush or pipe cleaner. For particularly absorbent substrates you can apply a second coat of product.

The epoxy primer **ARMOPRIMER 100** of DRACO Italiana S.p.A. must have the following features:

- Density of the mix: 1.1 g/cm<sup>3</sup>
- Brookfield viscosity (rotor 1 - rotations 10): 300 mPa-s
- Adhesion to concrete (after 7 days at +23°C): > 3 MPa (substrate failure)

**Consumption:** 200÷300 g/m<sup>2</sup> per coat depending on the porosity and irregularities of the substrate.

#### LAYING:

2) Fill the cavity by injecting **ARMOFIX MT** of DRACO Italiana S.p.A. (for horizontal application) or **ARMOFIX MTX** of DRACO Italiana S.p.A. (for vertical application); insert the aramid connector coupled with the carbon bar inside the hole. The aramid connector portion which has not been impregnated and comes out of the hole (thread) should be opened like a fan and fixed to the surface surrounding the hole by resin impregnation. Take a portion of **ARMOSHIELD C** of DRACO Italiana S.p.A. carbon fibre fabric of a size which enables the full covering of the thread and apply it over the first coat of resin while it is still fresh.



**ARMOFIX MT** of DRACO Italiana S.p.A., the epoxy adhesive for the bonding of pultruded plates, must have the following features (compliant with the minimum requirements of EN 1504-4):

FEATURES	PERFORMANCE	TEST METHOD
Ash content from direct calcination	0,5 %	UNI EN ISO 3451-1
TGA DSC (Thermogravimetry)	+84°C	UNI EN ISO 11358
Pot life	40'	UNI EN ISO 9514
Compressive strength	60 MPa	UNI EN 12190
Flexural modulus of elasticity	3100 MPa	UNI EN ISO 178
Shear strength	19,4 MPa	UNI EN 12188
Open time	60'	UNI EN 12189
Compressive modulus of elasticity	3200 MPa	UNI EN 13412
Glass transition temperature	84°C	UNI EN 12614
Coefficient of thermal expansion	26x10 <sup>-6</sup> /K	UNI EN 1770
Dry shrinkage	0,04%	UNI EN 12617-1
Suitability for injection	Split concrete	UNI EN 12618-2
Adhesion	Cohesive fracture concrete	UNI EN 12636
Shear durability after humidity and thermal exposure	Break concrete	UNI EN 13733

#### Consumptions:

approx 1.1 kg/m<sup>2</sup> per mm of thickness

The epoxy adhesive for the impregnation of fabrics **ARMOFIX MTX** of DRACO Italiana S.p.A. must have the following features (compliant with the minimum requirements of EN 1504-4):

FEATURES	PERFORMANCE	TEST METHOD
Ash content from direct calcination	2%	UNI EN ISO 3451-1
TGA DSC (Thermogravimetry)	+83°C	UNI EN ISO 11358
Pot Life	40'	UNI EN ISO 9514
Compressive strength	90 MPa	UNI EN 12190
Flexural modulus of elasticity	3100 MPa	UNI EN ISO 178
Shear strength	20,3 MPa	UNI EN 12188
Open time	40'	UNI EN 12189
Compressive modulus of elasticity	3200 MPa	UNI EN 13412
Glass transition temperature	83°C	UNI EN 12614
Coefficient of thermal expansion	25x10 <sup>-6</sup> /K	UNI EN 1770
Dry shrinkage	0,03%	UNI EN 12617-1
Suitability for injection	Split concrete	UNI EN 12618-2
Adhesion	Cohesive fracture concrete	UNI EN 12636
Shear durability after humidity and thermal exposure	Break concrete	UNI EN 13733

#### Consumptions:

Skimming: 1.4 - 1.6 kg/m<sup>2</sup> per mm of thickness

Bonding and impregnation of the fabrics - Average total thickness of about 1 mm:

approx. 1.1 kg/m<sup>2</sup> for a fabric layer of 300 g/m<sup>2</sup> - approx. 1.5 kg/m<sup>2</sup> for a fabric layer of 600 g/m<sup>2</sup>.

- Where a finishing is envisaged, quartz sand should be applied over the fresh resin coat.

**ARMOGRIP** connectors must have the following performance characteristics:

ARMOGRIP BC CONNECTORS	
Diameter	10-12 mm
Inner bar	Ø 8 mm
Strand tensile strength	2900 MPa
Modulus of elasticity	120 GPa
Elongation at breakage	2,5 %
AVAILABLE SIZES	
20 cm thread	A10F20 (connector length 10 cm) A20F20 (connector length 20 cm) A30F20 (connector length 30 cm)

## 4.8

## STRENGTHENING OF STRUCTURAL ELEMENTS WITH CARBON FIBRE PULTRUDED PLATES

**Structural strengthening and flexural seismic retrofitting of beams and supports for bridges and viaducts through pre-tensioning of carbon plates**

### PRE-TENSIONING OF ARMOSHIELD CFK PLATES

Supply and installation of **ARMOSHIELD CFK** of Draco Italiana S.p.A, the carbon fibre pre-tensioned pultruded plates pre-impregnated with high-density epoxy resin that shows high mechanical strength. They should be used for the reinforcement, static repair and plating of concrete and masonry elements subjected to compression and combined bending and axial load with no load increase. The plates should be laid by respecting the following procedure:

#### PREPARATION:

- Substrate preparation: remove the surface fluid cement grout and any damaged parts, stains, efflorescences, dirt and dust.
  - Substrate smoothing: remove roughness and fill the cavities in the bonding area.
- The concrete substrate must have a pull-off strength of at least 1.5 N/mm<sup>2</sup> and a flatness with a maximum deviation of 5mm/2m. Concrete removal is not required for the housing of the hydraulic jacks.

#### LAYING:

The plates should be laid by respecting the following procedure:

- 1) Cut the plates to the size needed according to the project requirements. Remove the protective film, if any, or clean both sides of the plate with **ARMOCLEANER CFK** of Draco Italiana S.p.A,.
- 2) Apply the epoxy primer **ARMOPRIMER 100** of DRACO Italiana S.p.A. on dry substrate by brush or roller.

The epoxy primer **ARMOPRIMER 100** of DRACO Italiana S.p.A. must have the following features:

- Density of the mix: 1.1 g/cm<sup>3</sup>
- Brookfield viscosity (rotor 1 - rotations 10): 300 mPa-s
- Adhesion to concrete (after 7 days at +23°C): > 3 MPa (substrate failure)

- 3) Apply the structural epoxy adhesive **ARMOFIX MTL** of DRACO Italiana S.p.A. by spatula. Skimming is necessary on irregular or non-planar surfaces having surface unevenness > 5 mm. It must be performed after the primer touch dry period has elapsed and in any case within 16 hours, by using the epoxy bonding adhesive **ARMOFIX MTL** of DRACO Italiana S.p.A. applied by spatula or trowel. Apply a first coat of **ARMOFIX MTL** bonding resin of DRACO Italiana S.p.A by spatula on the clean and dry surface and on the side of the plate to be bonded to the substrate, ranging in thickness from 1 to 3 mm.

The epoxy adhesive for the bonding of **ARMOFIX MTL** pultruded plates of DRACO of Italiana S.p.A. must have the following features (compliant with the minimum requirements of EN 1504-4):

FEATURES	PERFORMANCE	TEST METHOD
TGA DSC (Thermogravimetry)	67°C	UNI EN ISO 11358
Pot Life	90'	UNI EN ISO 9514
Compressive strength	92 MPa	UNI EN 12190
Flexural modulus of elasticity	6100 MPa	UNI EN ISO 178
Shear strength	19,4 MPa	UNI EN 12188
Open time	120'	UNI EN 12189
Compressive modulus of elasticity	6500 MPa	UNI EN 13412
Glass transition temperature	67°C	UNI EN 12614
Coefficient of thermal expansion	18x10 <sup>-6</sup> /K	UNI EN 1770
Dry shrinkage	0,04%	UNI EN 12617-1
Suitability for injection	Split concrete	UNI EN 12618-2
Adhesion	Cohesive fracture concrete	UNI EN 12636
Shear durability after humidity and thermal exposure	Break concrete	UNI EN 13733

#### Consumptions:

Skimming: 150 g/m<sup>2</sup> per mm of thickness Recommended thickness 1-3 mm

Plate bonding:

- 150-200 g/m for the bonding of 5-cm plate
- 240-320 g/m for the bonding of 8-cm plate
- 300-400 g/m for the bonding of 10-cm plate
- 360-480 g/m for the bonding of 12-cm plate

4) Position the steel plates and apply **ARMOSHIELD CFK** of DRACO Italiana S.p.A. pultruded carbon fibre plates. The **ARMOSHIELD CFK** of DRACO Italiana S.p.A. pre-tensioning system consists of perforated steel plates pre-treated against corrosion; it is installed on the beam to be strengthened by means of the special epoxy resin **ARMOFIX MTL** of DRACO Italiana S.p.A. Position the base plates as planned, fix them to the substrate by means of special segments and apply **ARMOSHIELD CFK** pultruded carbon fibre plates of DRACO Italiana S.p.A. over the steel plate and the fresh resin coat. Anchor the plate by positioning the movable wedge plates in order to block it during tensioning.

Lay the plate along the entire length of the beam and exert a slight pressure over the entire length of the plate.

The carbon fibre pultruded plates **ARMOSHIELD CFK** of Draco Italiana S.p.A. must have the following features:

FEATURES										
Density (g/cm <sup>3</sup> )	1,6									
Fibre content (%)	68									
Tensile modulus of elasticity (GPa)	160					210				
Thickness (mm)	1,2 (2pp)			1,4			1,4			
Width (mm)	50	80	100	50	80	100	50	80	100	120
Resistant section (mm <sup>2</sup> )	60	96	120	70	112	140	70	112	140	168
Tensile strength (MPa)	> 2400					> 2400				
Elongation at breakage (%)	1,36					0,95				

5) Tension the plate as planned with special hydraulic jacks coupled with the movable wedge plates. The pre-tensioning system, consisting of wedge plates and hydraulic jacks, must be removed after 24/48 hours following application and depending on the outdoor temperature, which must in any case be higher than 10°C. Suitable systems may be required for the pre-heating of the adhesion system and intervention area.

Lay a thin coat of adhesive along the entire length of the plate and sprinkle with quartz sand while the adhesive is still fresh.

## 4.9

## STRENGTHENING OF NON-STRUCTURAL ELEMENTS WITH CEMENT MATRIX AND FRP CONNECTORS

**Strengthening and seismic retrofitting of non-load-bearing masonry buffer walls, panels and floor slabs through anti-overturning and anti-collapse systems made of single-component mortars and bidirectional basalt fibre mesh**

Supply and installation of **ARMOTECH MONO** of Draco Italiana S.p.A., the high-ductile single-component mortar enriched with lime, and the bidirectional basalt fibre mesh **ARMONET B 250** of Draco Italiana S.p.A. They are ideal for the light reinforcement of masonry buffer walls, panels and floor slabs and for improving their anti-seismic performance.

The system should be laid by respecting the following procedure:

### PREPARATION

- Substrate preparation: remove the surface fluid cement grout and any damaged parts, stains, efflorescences, dirt and dust as indicated above.
- Substrate smoothing: remove roughness and fill the cavities in the bonding area.
- Smooth the surface by means of a suitable fibre-reinforced structural mortar **FLUECO 40T** of Draco Italiana S.p.A., two-component in case of weak supports **FLUECO 80 T2** of Draco Italiana S.p.A..

Supply and installation of **ARMOGRIP** of Draco Italiana S.p.A. anchoring devices made of high-strength aramid fibres for anchoring the reinforcement.

### ARRANGEMENT OF HOUSING HOLES

- Drill holes approximately every 2 metres on the intrados of the floor slab or along the perimeter of the panel in order to house **ARMOGIP** aramid fibre connectors of Draco Italiana S.p.A. The holes should have a diameter of about 20 mm and a depth of 10 cm (distance from the masonry: about 1.5 cm). Round the edges of the hole outer profile (minimum radius of 1cm), and remove dust and loose material by vacuum cleaner.

### PRIMING

- 1) Apply the epoxy primer **ARMOPRIMER 100** of DRACO Italiana S.p.A. inside the holes by brush or pipe cleaner. For particularly absorbent substrates you can apply a second coat of product.

The epoxy primer **ARMOPRIMER 100** of DRACO Italiana S.p.A. must have the following features:

- Density of the mix: 1.1 g/cm<sup>3</sup>
- Brookfield viscosity (rotor 1 - rotations 10): 300 mPa·s
- Adhesion to concrete (after 7 days at +23°C): > 3 MPa (substrate failure)

**Consumption:** 200÷300 g/m<sup>2</sup> per coat depending on the porosity and irregularities of the substrate

### LAYING

- 2) Inject **ARMOFIX MT** of DRACO Italiana S.p.A. (for horizontal application) or **EP FIX** of DRACO Italiana S.p.A. (for application in overhead positions) inside the hole taking care to fill half of it; insert **ARMOGRIP** aramid connector of DRACO Italiana S.p.A. inside the hole. Proceed with the impregnation and filling of the connector cavity for its entire length with the chosen resin.

**ARMOFIX MTX** of DRACO of Italiana S.p.A., the epoxy adhesive for the bonding of pultruded plates, must have the following features (compliant with the minimum requirements of EN 1504-4):

FEATURES	PERFORMANCE	TEST METHOD
Ash content from direct calcination	2%	UNI EN ISO 3451-1
TGA DSC (Thermogravimetry)	+83°C	UNI EN ISO 11358
Pot Life	40'	UNI EN ISO 9514
Compressive strength	90 MPa	UNI EN 12190
Flexural modulus of elasticity	3100 MPa	UNI EN ISO 178
Shear strength	20,3 MPa	UNI EN 12188
Open time	40'	UNI EN 12189
Compressive modulus of elasticity	3200 MPa	UNI EN 13412
Glass transition temperature	83°C	UNI EN 12614
Coefficient of thermal expansion	25x10 <sup>-6</sup> /K	UNI EN 1770
Dry shrinkage	0,03%	UNI EN 12617-1
Suitability for injection	Split concrete	UNI EN 12618-2
Adhesion	Cohesive fracture concrete	UNI EN 12636
Shear durability after humidity and thermal exposure	Break concrete	UNI EN 13733

#### Consumptions:

kimming: 1.4 - 1.6 kg/m<sup>2</sup> per mm of thickness

Bonding and impregnation of the fabrics - Average total thickness of about 1 mm:

approx. 1.1 kg/m<sup>2</sup> for a fabric layer of 300 g/m<sup>2</sup> - approx. 1.5 kg/m<sup>2</sup> for a fabric layer of 600 g/m<sup>2</sup>.

**ARMOGRIP** connectors must have the following performance characteristics:

ARMOGRIP CONNECTORS	
Diameter	12 mm
Strand tensile strength	2900 MPa
Modulus of elasticity	120 GPa
Elongation at breakage	2,5 %
Connector tensile strength	56 kN
Strand section	0,239 cm <sup>2</sup>
AVAILABLE SIZES	
20 cm thread	A10F20 (connector length 10 cm) A20F20 (connector length 20 cm) A30F20 (connector length 30 cm)
30 cm thread	A50F30 (connector length 50 cm)

#### REINFORCEMENT APPLICATION

**3)** Supply and installation of **ARMOTECH MONO** of Draco Italiana S.p.A., the high-ductile single-component mortar with superior mechanical strength compatible with masonry, enriched with lime and based on selected aggregates and special additives. It is ideal for the light reinforcement of masonry buffer walls and floor slabs and for improving their anti-seismic performance.

- The substrate should be properly cleaned by removing all loose, damaged and crumbling parts. The mortar should be applied by spatula on the clean substrate saturated with water, creating a thickness between 3 to 4mm per layer.

**Consumption:** approx 1.6 kg/m<sup>2</sup> per mm of thickness

## 4.9

The one-component mortar enriched with lime type **ARMOTECH MONO** of DRACO Italiana S.p.A. must have the following performance characteristics:

(classified as class R2 mortars in accordance with EN 1504-3 and EN 998-2)

FEATURES	TEST METHOD	PERFORMANCE
Compressive strength (MPa)	EN 12190	22 MPa at 28 days
Flexural strength (MPa)	EN 196/1	6 MPa at 28 days
Compressive modulus of elasticity (GPa)	EN 13412	12 GPa
Bond strength on concrete (substrate type MC 0,40 w/c ratio = 0.40 ) according to EN 1766	EN 1542	> 1,5 MPa
Capillary absorption (kg/m <sup>2</sup> ·h <sup>0.5</sup> )	EN 13057	0,31 kg/m <sup>2</sup> ·h <sup>0.5</sup>
Thermal compatibility measured as bond strength according to EN 1542 (MPa) on concrete MC 0,4 UNI EN 1766 - Freeze-thaw cycles with de-icing salts	EN 13687/1	> 0,8 MPa
Reaction to fire	EN 13501-1	A2
Compressive strength after 28 days (MPa)	EN 1015-11	Class M20
Bond strength	EN 1052-3	0,15 MPa
Water absorption	EN 1015-18	< 0,2 kg/m <sup>2</sup> ·h <sup>0.5</sup>
Permeability to water vapour	EN 1745:2002, prospect A.12	μ 5/20
Bulk volume	EN 1015-10	1780 kg/m <sup>3</sup>
Thermal conductivity	EN 1745:2002, prospect A.12	0,45 W/mK

4) Apply **ARMONET B 250** basalt fibre mesh of DRACO Italiana S.p.A., cut to the size needed, over the first layer of mortar while it is still fresh. Any cold joint should be made through simple overlap of at least 10 cm. Packaging: 1x50 m rolls.

The **ARMONET B 250** basalt fibre mesh product of DRACO Italiana S.p.A. must have the following performance characteristics:

FEATURES	
Appearance	Bidirectional basalt fibre mesh balanced at 0/90° Impregnated - alkali resistant fabric wrap
Mesh weight per unit of area	approx. 250 g/m <sup>2</sup>
Resistant area per unit width	Axis 0° - 32,38 mm <sup>2</sup> /m Axis 90° - 35,95 mm <sup>2</sup> /m
Maximum load per unit width	Axis 0° - 78 kN/m Axis 90° - 86 kN/m
Mesh size (centre to centre distance)	mm 10 x 10
Tensile strength (strand)	2418 MPa
Modulus of elasticity (strand)	87 GPa
Elongation at breakage (strand)	3,5%

5) Lay an additional coat of **ARMOTECH MONO** of DRACO Italiana S.p.A. of about 3 mm over the mortar which has not yet hardened and on the mesh by uniformly covering it. For any subsequent layers, repeat the process always using the wet-on-wet technique.

6) **Connector anchoring:** The aramid connector portion which has not been impregnated and comes out of the hole (thread) should be opened like a fan and fixed to the surface surrounding the hole by resin impregnation.



# ARMO: FRP SYSTEMS FOR REINFORCING AND STRENGTHENING STRUCTURES

Full range of materials for the restoration and the reinforcement of structures made of reinforced concrete, pre-stressed reinforced concrete, masonry, wood and steel

## CARBON FIBRE PLATES AND FABRICS

### ARMOSHIELD C-SHEET

**VERY FLAT UNIDIRECTIONAL FABRIC MADE OF HIGHLY RESISTANT CARBON FIBRES FOR STRUCTURAL STRENGTHENING**

ARMOSHIELD C-SHEET is a very flat unidirectional fabric made of carbon fibres and high-density FRP composite materials that show high modulus of elasticity and develop high mechanical strength. It should be used in combination with specific ARMOFIX resins for static reinforcement and repair of building structures with no load increase. The ARMOSHIELD C-SHEET fabrics are supplied in tapes made of top quality carbon fibres that are arranged in a single direction and lie perfectly flat. They are particularly suitable for confining structures exposed to compression and bending, such as beams and columns and for reinforcing cutting beams.

#### CHARACTERISTICS

Elastic modulus (GPa): 240 - 390  
Weight (g/m<sup>2</sup>): 300 - 600  
Available widths (cm): 10-20-40-60

#### PACKAGING

50 m rolls



### ARMOSHIELD C-B

**HIGHLY RESISTANT BIDIRECTIONAL FABRIC MADE OF CARBON FIBRES FOR STRUCTURAL STRENGTHENING AND CONSOLIDATION**

ARMOSHIELD C-B is a bidirectional fabric made of carbon fibres and high-density FRP composite materials that show high modulus of elasticity and develop high mechanical and tensile strength. It should be used in combination with specific ARMOFIX resins for static reinforcement and repair of building structures. ARMOSHIELD C-B increases the strength, load bearing capacity and ductility of structures without increasing the load. It is particularly suitable for restoring sections that show shear strength or areas where you may need to integrate longitudinal reinforcing bars.

#### CHARACTERISTICS

Elastic modulus (GPa): 250  
Weight (g/m<sup>2</sup>): 320  
Available widths (cm): 10-20-50

#### PACKAGING

50 m rolls

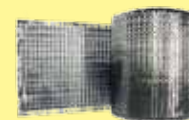

### ARMOSHIELD C-QUADRAX

**HIGHLY RESISTANT QUADRIAXIAL CARBON FIBRE FABRIC WITH HIGH MODULUS OF ELASTICITY FOR STRUCTURAL STRENGTHENING**

ARMOSHIELD C-QUADRAX is a quadriaxial fabric made of carbon fibres and high-density FRP composite materials that show high modulus of elasticity and develop high mechanical and tensile strength. It should be used in combination with specific ARMOFIX resins for static reinforcement and repair of building structures. ARMOSHIELD C-QUADRAX increases the strength, load bearing capacity and ductility of structures without increasing the load. It is particularly suitable for restoring discontinuous structures or sections where it is not possible to exactly determine the tensile stress.

#### CHARACTERISTICS

Elastic modulus (GPa): 235 - 240  
Weight (g/m<sup>2</sup>): 380 - 760  
Available widths (cm):  
• 31,5-42 (380 g/m<sup>2</sup> - 235 GPa)  
• 31,75-62,5 (760 g/m<sup>2</sup> - 240 GPa)

#### PACKAGING

50 m rolls



### ARMOSHIELD CFK

**UNIDIRECTIONAL PULTRUDED CARBON FIBRE PLATES WITH SUPERIOR STRENGTH FOR REINFORCING AND PLATING CONCRETE, STEEL AND WOOD**

Line of pultruded carbon fibre plates for strengthening concrete structures in reinforced and pre-stressed reinforced concrete, steel and wood to be used in combination with the specifically designed ARMOFIX MTL resins and ARMOSHIELD C tapes. ARMOSHIELD CFK plates are ideal for reinforcement even with pre-tensioning. Thanks to their lower weight and improved performance, they are an excellent substitute for the traditional beton plaque systems in thicknesses from approx. 1-3 mm.

#### CHARACTERISTICS

Elastic modulus (GPa): 160 - 210  
Thickness (mm): 1.2 - 1.4  
Available widths (cm): 5-8-10-12

#### PACKAGING

50 m rolls





## CONNECTORS, BARS AND ANCHORING SYSTEMS BASED ON FRP COMPOSITE MATERIALS

### ARMOGRIP

#### ARAMID CONNECTORS FOR STRUCTURAL ANCHORING OF ARMOSHIELD CARBON FIBRE TAPES

Aramid fibre anchoring chords woven in bundles around a spring to improve connection and enhance reinforcement carried out with ARMOSHIELD carbon fibre fabrics.

#### CHARACTERISTICS

20 cm tape:  $\varnothing$  12 mm  
Connector length (cm): 10-20-30-50

#### PACKAGING



### ARMOGRIP BC

#### ARAMID CONNECTOR COUPLED WITH ARMOSHIELD BC CARBON BAR FOR ANCHORING STRUCTURAL REINFORCEMENTS

Anchoring chords of braided aramid fibre bundles combined with ARMOSHIELD BC pultruded bars for connecting and enhancing reinforcements with ARMOSHIELD C reinforcing fabrics.

#### CHARACTERISTICS

20 cm tape:  $\varnothing$  12 mm  
Inner bar:  $\varnothing$  8 mm  
Connector length (cm): 10-20-30

#### PACKAGING



### ARMOGRIP MONO

#### ONE DIRECTIONAL CHORD IN ARAMID FIBRE FOR CONNECTING STRUCTURAL REINFORCEMENTS

The aramid fibre chords ARMOGRIP MONO are ideal for anchoring and connecting structures when reinforcing structures with the ARMOSHIELD line. They are available in diameters of 6, 8, 10 and 12 mm and are applied by simply impregnating them with ARMOFIX MTX.

#### CHARACTERISTICS

Available diameters:  $\varnothing$  6-8-10-12 mm

#### PACKAGING

10 m roll



### ARMOGRIP TB

#### BRAIDED ARAMID FIBRE STOCKING FOR STRUCTURAL ANCHORING OF ARMOSHIELD CARBONFIBRE STRIPS

Aramid fibre anchoring chord woven in bundles around an inner plastic tube to improve connection and enhance reinforcement carried out with the ARMOSHIELD carbon fibre fabric.

#### CHARACTERISTICS

Available diameters:  $\varnothing$  12 mm

#### PACKAGING

10 m roll



### ARMOSHIELD BC

#### HIGH-STRENGTH CARBON FIBRE PULTRUDED BARS FOR REINFORCING AND CRAMPING BRICK AND CONCRETE STRUCTURES

High-strength carbon fibre pultruded bars to strengthen reinforced concrete, pre-stressed reinforced concrete, brick, stone, and natural material buildings. ARMOSHIELD BC bars may be used in combination with ARMOSHIELD C fabric and ARMOGRIP TB aramid threads to improve connections and anchoring of carbon fibre fabrics to reinforced surfaces.

#### CHARACTERISTICS

Available diameters:  $\varnothing$  8-10-12-14-16 mm

#### PACKAGING

PVC tubes containing 19-24 (3 m Bars)



### ARMONET B 250

#### ALKALI RESISTANT BASALT FIBRE MESH FOR STRUCTURAL STRENGTHENING OF LOAD-BEARING CONCRETE AND MASONRY ELEMENTS

ARMONET B 250 is an impregnated basalt fibre mesh that is alkali resistant for structural reinforcement. It is specifically designed to be used in combination with FLUECO mortars or ARMOTECH MONO. ARMONET B 250 improves the distribution of stress enhancing the overall ductility of the structures that are being reinforced or undergoing seismic retrofitting.

#### CHARACTERISTICS

Meshing: 10x10 mm  
Specific weight: 250 g/m<sup>2</sup>

#### PACKAGING

1x50 m roll (50 m<sup>2</sup>)



## EPOXY-BASED REINFORCING AGENTS AND PRIMERS

### ARMOPRIMER 100

#### TWO-COMPONENT SOLVENT-FREE EPOXY PRIMER WITH LOW ENVIRONMENTAL IMPACT

ARMOPRIMER 100 is a fluid -based product based on epoxy resins with strong consolidating capacity. It penetrates deeply to consolidate the total area of porous concrete and masonry promoting the adhesion of the subsequent cycle of ARMOSHIELD carbon fibre bonding tapes. For particularly absorbent/porous substrates use the version insolvent phase, PRIMER ES40.

#### CHARACTERISTICS

1 kg Pail + 0.5 kg Pail = (A + B) 1.5 kg  
6 kg Pail + 3 kg Pail = (A + B) 9 kg  
12 kg Pail + 6 kg Pail = (A + B) 18 kg

#### PACKAGING

200 ÷ 300 g/m<sup>2</sup>  
per coat depending on the porosity of the substrate



## SPECIAL ADHESIVES AND RESINS FOR COMPOSITE STRENGTHENING SYSTEMS (FRP)

### ARMOFIX MTL

#### TWO-COMPONENT EPOXY RESIN FOR STRUCTURAL BONDING OF ARMOSHIELD CFK CARBON FIBRE STRIPS

ARMOFIX MTL is a two-component adhesive based on epoxy resins, selected fine-grain aggregates and thixotropic agents specifically designed for bonding ARMOSHIELD CFK pultruded carbon fibre plates. ARMOFIX MTL exhibits strong adhesion to all building materials and may be used for bonding and structural reinforcement.

#### CHARACTERISTICS

2.5 kg Pail + 2.5 kg Pail = (A + B) 5 kg  
5 kg Pail + 5 kg Pail = (A + B) 10 kg

#### PACKAGING

To apply 1 m<sup>2</sup> of ARMOSHIELD CFK strips we recommend approx.1.5 kg of ARMOFIX MTL per mm of thickness



### ARMOFIX MTX

#### TWO-COMPONENT THIXOTROPIC EPOXY RESIN FOR STRUCTURAL BONDING OF ARMOSHIELD CARBON FIBRE FABRICS

ARMOFIX MTX is a two-component structural resin. It is specifically designed to impregnate and bond ARMOSHIELD C carbon fibre tapes. Its unique "GEL formulation" makes fabric saturation easy and quick and provides excellent adhesion to any substrate.

#### CHARACTERISTICS

4 kg Pail + 1 kg Pail = (A+B) 5 kg  
8 kg Pail + 2 kg Pail = (A+B) 10 kg

#### PACKAGING

1.1 ÷ 1.5 kg/m<sup>2</sup>  
depending on the type of fabric



### ARMOFIX MT

#### FLUID TWO-COMPONENT EPOXY RESIN FOR IMPREGNATION OF ARMOSHIELD C FABRIC BY IMMERSION, GROUTING ARMOSHIELD BC BARS AND FOR HORIZONTAL APPLICATION OF ARMOGRIP CONNECTORS

ARMOFIX MT is a two-component fluid epoxy resin specifically formulated to be used as an adhesive and plaster. ARMOFIX MT is free of solvents, plasticizers and diluents and exhibits strong adhesion to all building materials. It enables you to carry out structural bonding, grouting and repairs in cavities. ARMOFIX MT cures without shrinkage even in moist environments.

#### CHARACTERISTICS

6.9 kg Pail + 2.4 Pail = (A + B) 8.4 kg  
11 kg Pail + 4.4 Pail = (A + B) 15.4 kg

#### PACKAGING

1.1 kg/m<sup>2</sup> approx. per mm of thickness



## FIBRE-REINFORCED CEMENT MORTARS

### ARMOTECH MONO

#### HIGHLY-DUCTILE, LIME-RICH THIXOTROPIC FIBRE-REINFORCED MORTAR

ARMOTECH MONO is a high strength mortar with superior bonding strength based on binders and pozzolanic reagents for the repair and strengthening of masonry and vaults in brick, clay-brick, stone or tuff. It is compatible with the materials used for building very old walls and is hence ideal for the recovery of historical buildings. ARMOTECH MONO may be used in conjunction with the alkali-resistant basalt fibre mesh ARMONET B 250 for the reinforcement of walls even when subjected to movement. The use of this product coupled with the mesh permits a uniform distribution of tensile stress caused by movement in the structure and prevents chipping and cracking.

#### CHARACTERISTICS

25 kg Bag

#### PACKAGING

16 kg/m<sup>2</sup> approx.  
per cm of thickness



### FLUECO 80 T2

#### TWO-COMPONENT THIXOTROPIC FIBRE-REINFORCED MORTAR WITH LOW ELASTIC MODULUS AND SHRINKAGE COMPENSATION

*Ideal for structural restorations in highly aggressive environments and in the presence of load deformation*

FLUECO 80 T2 is a two-component, fibre-reinforced cementitious mortar that is pre-mixed with water to obtain shrinkage-compensating thixotropic mixes. FLUECO 80 T2 develops high initial and final mechanical strength, has low elastic modulus and is waterproof. It is longlasting even in highly aggressive environments and ensures strong bonding. It contains no metal parts or chlorides. FLUECO 80 T is resistant to chemical and environmental attack and its stability does not depend on the formation of air or gas.

#### CHARACTERISTICS

25 kg Bag + 5 kg Can = (A + B) 30 kg

#### PACKAGING

21.5 kg/m<sup>2</sup> approx.  
per cm of thickness



### FLUECO 40 T

#### NANO POLYMERIC THIXOTROPIC, FIBRE-REINFORCED CEMENT MORTAR WITH SHRINKAGE COMPENSATION AND HIGH RESISTANCE FOR STRUCTURAL RESTORATION

*Easy to use for layer thickness up to 5 cm thick without electro-welded mesh*

FLUECO 40 T is a single component, nano-polymeric, fibre-reinforced, cementitious mortar that is mixed with water to obtain non-segregatable, shrinkage-compensating thixotropic mixes. FLUECO 40 T develops high initial and final mechanical strength and is waterproof. It is longlasting even in aggressive environments and ensures strong bonding. It contains no metal parts or chlorides. FLUECO 40 T is resistant to chemical and environmental attack and is suitable for all the classes of exposure envisaged by UNI 11104.

#### CHARACTERISTICS

25 kg Bag

#### PACKAGING

17.4 kg/m<sup>2</sup> approx.  
per cm of thickness



## RELATED PRODUCTS

### ARMOROLLER

#### METAL ROLLER SPECIFICALLY DESIGNED FOR THE APPLICATION OF ARMOSHIELD C CARBON FIBRE FABRICS

The cross grooves enhance the impregnation of the fabric warp with the special ARMOFIX resins.

#### PACKAGING

Metal roller



### ARMOCLEANER CFK

Specific diluting agent for removing surface residues and carbon dust from ARMOSHIELD CFK plates. The plates should be cleaned on both sides with a cloth before bonding.

#### PACKAGING

1 l Bottle



Product	Name	Type	Resin impregnation/ bonding/mortar	Support
<b>FABRICS</b>	ARMOSHIELD C-SHEET	carbon - unidirectional fabrics	ARMOFIX MTX	concrete masonry wood
	ARMOSHIELD C-B	carbon - bidirectional fabrics	ARMOFIX MTX	
	ARMOSHIELD C-QUADRAX	carbon - quadraxial fabrics	ARMOFIX MTX	
<b>CARBON FIBRE PLATES</b>	ARMOSHIELD CFK LAMELLE	carbon - unidirectional pultruded carbon fibre plates	ARMOFIX MTL	concrete masonry wood steel
<b>CONNECTORS</b>	ARMOGRIP/ARMOGRIP MONO	aramid	ARMOFIX MT - MTX	concrete masonry
<b>BARS</b>	ARMOSHIELD BC	carbon	ARMOFIX MT - MTX	concrete masonry
<b>CONNECTOR + BAR</b>	ARMOGRIP BC	carbon/aramid	ARMOFIX MT - MTX	concrete masonry
<b>FIBRE MESH</b>	ARMONET B 250	basalt	ARMOTECH MONO	masonry

	Structural reinforcement					Structural improvement anti-overturning/anti-collapse		
<i>Fabrics/fibre mesh/bars</i>	FLUECO 40T / FLUECO 80 T2	ARMOFIX MTX	ARMOFIX MTL	ARMOFIX MT	ARMOGRIP	ARMOTECH MONO	ARMOGRIP	ARMOFIX MTX
ARMOSHIELD C-SHEET	✓	✓			✓			
ARMOSHIELD C-B	✓	✓			✓			
ARMOSHIELD C-QUADRAX	✓	✓			✓			
ARMOSHIELD CFK LAMELLE	✓		✓					
ARMONET B 250						✓	✓	✓
ARMOSHIELD CB		✓		✓	✓			
<b>Supports</b>								
CONCRETE	✓	✓	✓	✓				
MASONRY	✓	✓	✓	✓	✓	✓	✓	✓
WOOD		✓	✓					







**DRACO Italiana S.p.A**

Via Monte Grappa 11 D-E, I-20067 Tribiano (MI)

Tel. +39 0290632917- Fax. +39 0290631976

info@draco-edilizia.it

**draco-edilizia.com**



QUALITY YOU CAN BUILD ON

Follow us on:

